



# TECHNICAL DATASHEET

## UE Head Foam 350

Item Code : PFPFME001110

The EU Head Foam is particularly impressive for the importance of its flow. Efficient and easy to implement, this foam machine will seduce you to create sets or make giant animations. The foam produced is very ventilated which allows to breathe without problem even in case of immersion. Delivered complete with its pump on support and all necessary hoses.

### NOMENCLATURE :

- 1 x UE Head Foam 350
- 1 x Foam Net 350
- 1 x Strapping 350
- 1 x Pump 350
- 1 x Hose Kit

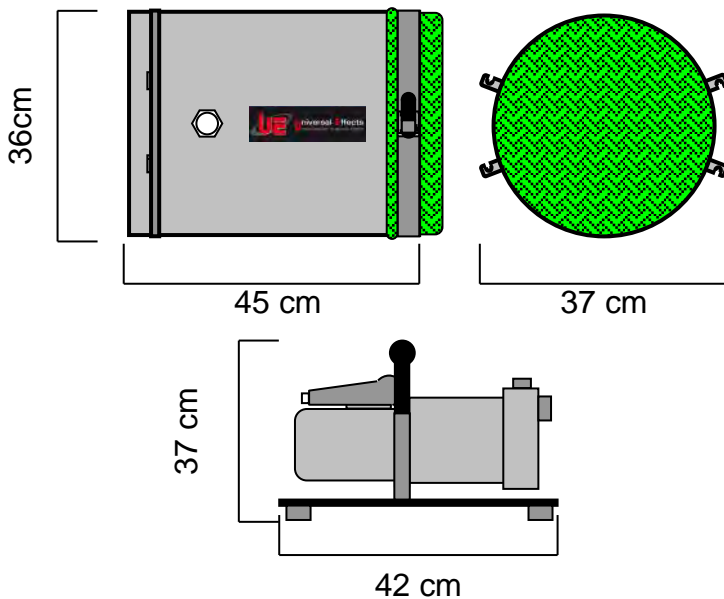

### TECHNICAL SPECIFICATIONS :

Size : 45 x 37 x 36 cm  
Weight : 25.4 Kg

### NECESSARY ACCESSORIES :

Pump 350:      Size : 42 x 23 x 37 cm  
                         Weight : 14,6 Kg  
                         Electrical Specifications :  
                         230V – 50Hz – 800W – 3,7A – IP 44

Hose Kit :      Hoses Lenght : 5 m and 7 m  
                         Hoses Weight : 5,6 kg

### BASES USABLE :

- UE K- Base 350
- UE ST- Base 350

### CONSUMPTION AND PRODUCTION :

- On UE K- Base 350 production of 50 m<sup>3</sup> / min of foam.
- On UE ST- Base 350 production of 70 m<sup>3</sup> / min of foam.
- Liquid consumption with CC foam: 1.2 L / min
- Consumption in water + fluid preparation: 60 L / mn

### CONSUMABLES :

- XT- Foam Fluid CC Diluted à 98% in water.
- XT- Foam Fluid HC Diluted à 99.5% in water.
- XT- Foam Fluid LC Diluted à 97% in water.

**Universal Effects, La qualité et l'innovation Fabriqué en France**

Universal Effects est une Marque fabriquée et distribuée par la société Premium Factory SAS  
1 Route Neuve, 71710 MONTCENIS - FRANCE | Email info@premiumfactory.eu | www.premiumfactory.eu  
Société Anonyme Simplifié au capital de 1 000 € | Siret 840 703 797 00018 | VAT Nr: FR47840703797