



TECHNICAL DATASHEET

UE Head Foam 500

Item Code : PFPFME001210

The UE Head Foam is particularly impressive for the importance of its flow. Efficient and easy to implement, this foam machine will seduce you to create sets or make giant animations.

The foam produced is very ventilated which allows to breathe without problem even in case of immersion.

Delivered complete with its pump on support and all necessary hoses.

NOMENCLATURE :

- 1 x UE Head Foam 500
- 1 x Pump 500
- 1 x Hose kit
- 1 x Foam net 500
- 1 x Strapping 500

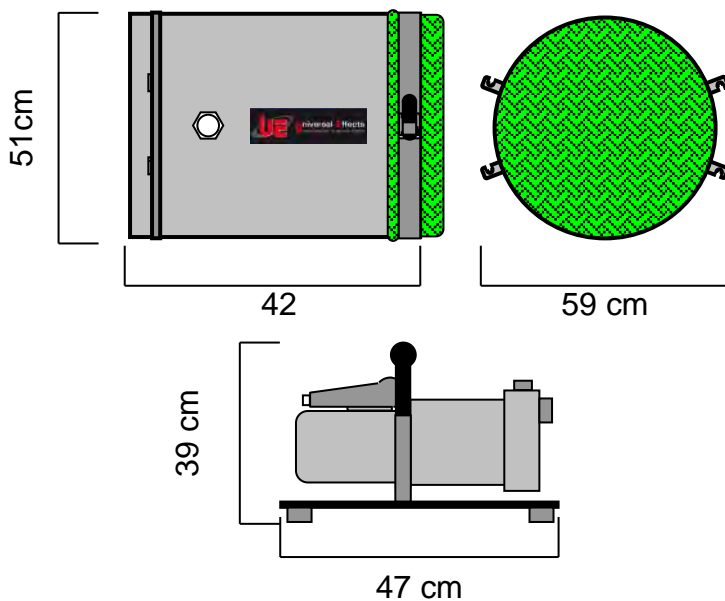

TECHNICAL SPECIFICATIONS :

Size : 42 x 59 x 51 cm
Weight : 29.4 Kg

ACCESSORIES NEEDED :

Pump 500: Size : 47 x 34 x 39 cm
 Weight : 17,4 Kg
 Electrical Specifications :
 230V – 50Hz – 1300W – 6,1A – IP 44

Hose Kit : Hoses Length : 5 m et 7 m
 Hoses Weight : 5,6 kg

BASE USABLE :

- UE ST- Base 500

CONSUMPTION AND PRODUCTION:

- On UE ST- Base 500 production of 180 m³ / min of foam.
- Liquid consumption with CC foam: 2,4 L / mn
- Consumption in water + fluid preparation: 120 L / mn

CONSUMABLES :

- XT- Foam Fluid CC Diluted à 98% in water.
- XT- Foam Fluid HC Diluted à 99.5% in water.
- XT- Foam Fluid LC Diluted à 97% in water.

Universal Effects, La qualité et l'innovation Fabriqué en France

Universal Effects est une Marque fabriquée et distribuée par la société Premium Factory SAS
1 Route Neuve, 71710 MONTCENIS - FRANCE | Email info@premiumfactory.eu | www.premiumfactory.eu
Société Anonyme Simplifié au capital de 1 000 € | Siret 840 703 797 00018 | VAT Nr: FR47840703797