



# TECHNICAL DATASHEET

## UE Head Mist & Rain 500

Item Code : PFPFRA001214

The UE Head Mist and Rain allows you to create your own weather. To refresh the mood, project water in mist mode. When you need to create a well-watered scene with wind, switch to rain mode. Effect used in cinema, video production and theme park. Delivered complete with its pump on support and all necessary hoses.

### NOMENCLATURE :

- 1 x UE Head Mist & Rain 500
- 1 x Pump 500
- 1 x Hose Kit

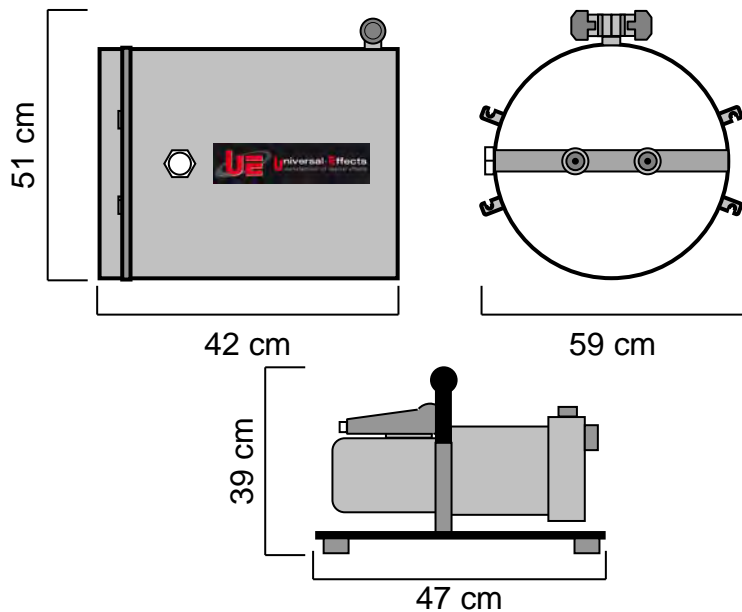

### TECHNICAL SPECIFICATIONS :

Size : 42 x 59 x 51 cm  
Weight : 32.8 Kg

### NECESSARY ACCESSORIES:

Pump 500:                    Size : 47 x 34 x 39 cm  
   Weight : 17,4 Kg  
   Electrical Specifications :  
   230V – 50Hz – 1300W – 6,1A

Hose Kit :    Length : 5 m and 7 m  
   Weight : 5,6 kg

### BASES USABLE :

- UE ST- Base 500
- UE XT- Base 500

### CONSUMPTION :

- On EU ST / XT- Base 500 mist cloud projection at 10m.
- Water consumption with mist nozzle: 6L / mn
- On EU ST / XT- Base 500 rain projection at 10m.
- Water consumption with 2 rain nozzles: 74L / mn

### CONSUMABLE :

water (provide storage barrel).

**Universal Effects, La qualité et l'innovation Fabriqué en France**

Universal Effects est une Marque fabriquée et distribuée par la société Premium Factory SAS  
1 Route Neuve, 71710 MONTCENIS - FRANCE | Email info@premiumfactory.eu | www.premiumfactory.eu  
Société Anonyme Simplifié au capital de 1 000 € | Siret 840 703 797 00018 | VAT Nr: FR47840703797