

SCHEMA TECHNIQUE – UE JET-CO2 DUO STD

(Avec CONTROLLER SAFETY PACK)

JET DE GAZ
CRYOGENIQUE CO2

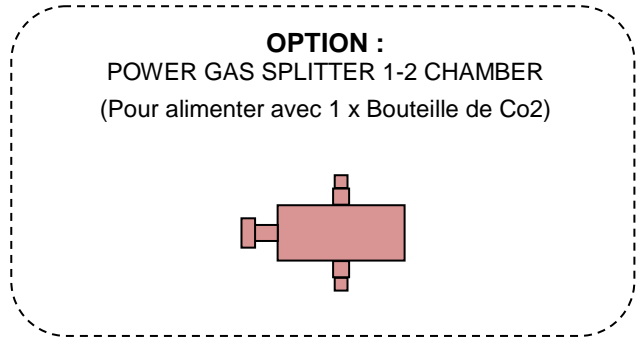
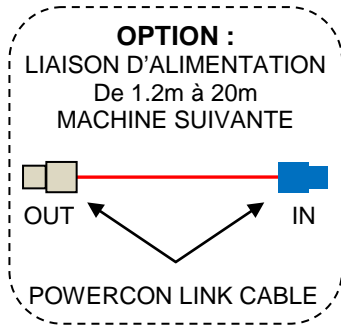
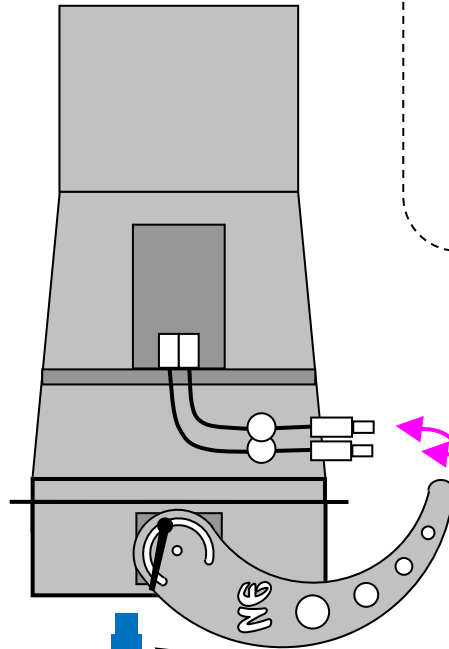
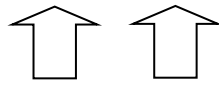

2 x
GAS HP-PIPE

2 x
Bouteille de CO2
avec tube plongeur
(Bouteille non inclus ;
Demandez notre contrat
de Gaz Partenaire)

POWERCON
LINK CABLE

CABLE DMX-512 IN/OUT
VERS CONSOLE D'ECLAIRAGE

CONTROLE 1^{er} CIRCUIT

CONTROLE 2^{eme} CIRCUIT

1 x
UE CONTROLLER
DMX 16A 2 OUT-CO2

Alimentation
Electrique
220V – 50Hz
5 mètres

1 x
UE DETECTOR-CO2
CABLE

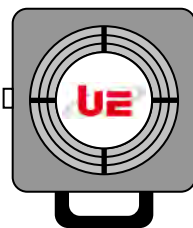

1 x
UE LEVEL
DETECTOR-CO2

2 x
UE
CONNECTION
SYSTEM CO2

OU
2 x
CONNECTION ECO

Connector

OPTION CONTROLLER SAFETY PACK

SCHEMA TECHNIQUE – UE JET-CO2 DUO STD/DMX

JET DE GAZ
CRYOGENIQUE CO2

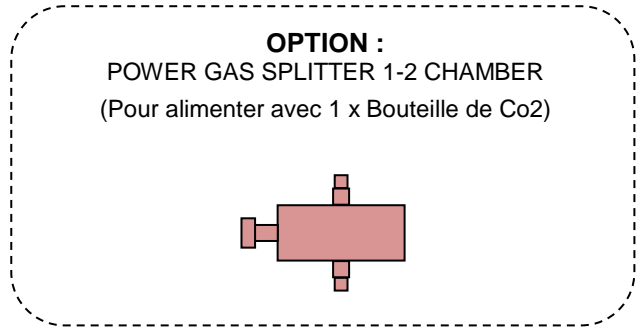
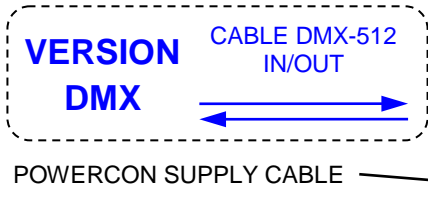
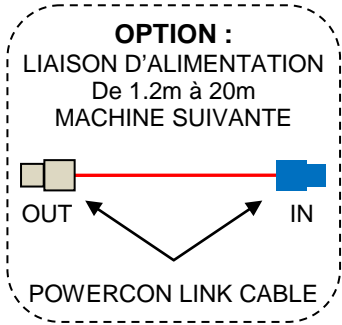
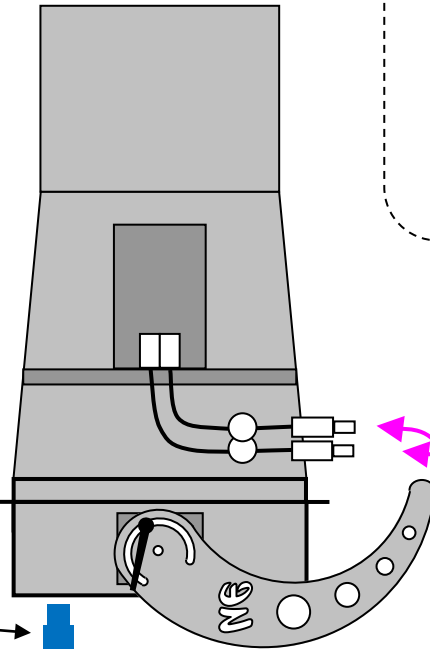
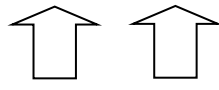

2 x
Bouteilles de CO2
avec tube plongeur
(Bouteille non inclus ;
Demandez notre contrat
de Gaz Partenaire)

OPTION INTERFACE SAFETY PACK

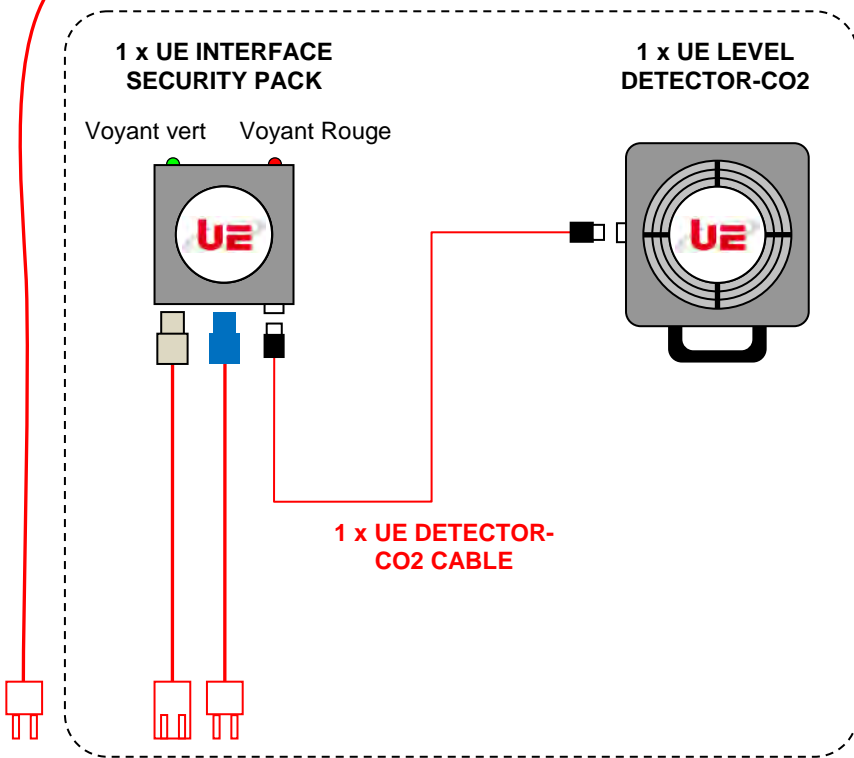

Alimentation
Electrique
220V – 50Hz

2 x
UE
CONNECTION
SYSTEM CO2

OU
2 x
CONNECTION ECO

