

## UE ST- Base 500 STD

Item Code : PFPFBA001222

The UE ST-Base 500 is very powerful and equipped with our traditional professional base that allow using on the ground, elevated foot, shoot tower or hang under a structure. It is also suitable for service companies and for fixed installations designed to operate inside and outside. ST-Power Base 500 STD include speed variation and is equipped with professional connectors and a resettable fuse.

### NOMENCLATURE :

- 1 x UE ST- Base 500 STD
- 5 x Tightenig buttons for heads
- 1 x PowerCon cable 5m



### TECHNICAL SPECIFICATIONS :

Size : Lg 56 x lg 79 x Hg 79 cm - Weight: 38 Kg

Electrical Characteristics :  
230V – 50/60Hz – 1500W – 6.5A – IP 55

Comply with norm CE ERP 2015

### CHARACTERISTICS :

- Sound 91 dB / 3m inside.
- Sound 81 dB / 3m outside.
- Standard base ground.
- Ajustment on 110° vertical.
- Can be hung under structure.
- Electronic speed variation integrated in the base.
- Base control + Head for manual Switch.

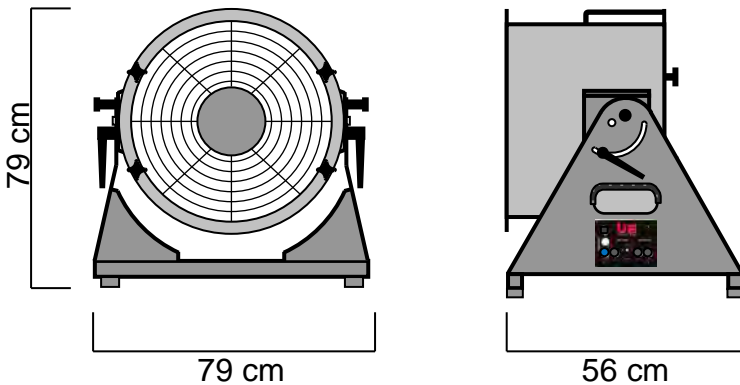

### USABLE HEADS:

- |                       |                         |
|-----------------------|-------------------------|
| UE Head Foam 500      | UE Head Jet-Foam 500    |
| UE Head Snow 500      | UE Head Mist&Rain 500   |
| UE Head Twin 500      | UE Head Wind 500        |
| UE Head Fragances 500 | UE Head Jet-Bubbles 500 |
| UE Head AirFlame 500  | UE Head Projection 500  |

### OPTIONAL ACCESSORIES :

- UE Skate Board 500
- UE Feet 50, 70, 100 (x 4)
- UE Shoot Tower 500

Manufactured in ALUMINIUM and STAINLESS, UE ST-Base 500 STD is done for last. Each element was chosen for his quality and efficiency.

**Universal Effects, La qualité et l'innovation Fabriqué en France**



# TECHNICAL DATASHEET

## UE Head Fragrance 500 Mono

Item Code : PFPFFR001215

The UE Head Fragrance incorporates a high performance and precise technology in terms of fragrance diffusion. Thanks to its power, the Fragrance head allows you to change perfume in a few seconds and distribute them in all types of volumes. Using 100% natural essential oils, you will create a fourth dimension and use a rarely used Sense: smell. Available in mono, duo and quattro for more choice and power.

### NOMENCLATURE :

- 1 x UE Head Fragrance 500 Mono



### TECHNICAL SPECIFICATIONS :

Size : 42 x 63 x 51 cm

Weight : 10.4 Kg

Electrical Specifications :  
230V – 50/60Hz – 22W – 0.1A – IP 44

Equipped with one diffusers of 20ml.

### FEATURES :

Equipped with a door for easy access to the diffuser for filling and cleaning.  
Designed for horizontal use only.  
Integrated electronic control with TIMER and DMX..

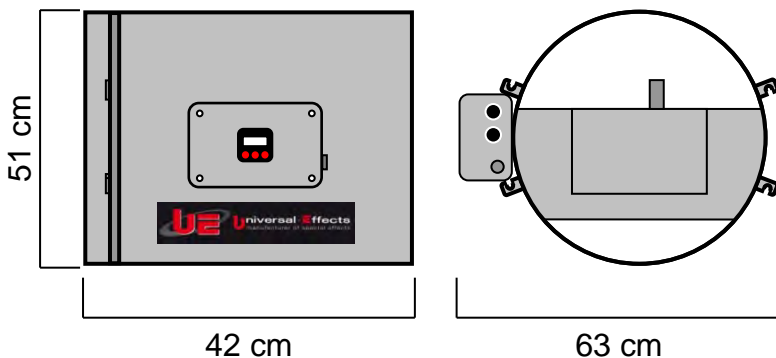

### OPTIONAL ACCESSORIES :

- Large capacity diffuser 50 ml

### CONSUMPTION :

The consumption varies according to the essential oil used, on average: 1 ml / h per diffuser.

### CONSUMABLES :

Perfume compositions specially formulated and adapted by Universal-Effects for its machines.

Made of ALUMINUM and INOX, the UE Head Fragrance 500 Mono is built to last. Each element has been chosen for its quality and efficiency.

**Universal Effects, La qualité et l'innovation Fabriqué en France**

Universal Effects est une Marque fabriquée et distribuée par la société Premium Factory SAS  
1 Route Neuve, 71710 MONTCENIS - FRANCE | Email info@premiumfactory.eu | www.premiumfactory.eu  
Société Anonyme Simplifié au capital de 1 000 € | Siret 840 703 797 00018 | VAT Nr: FR47840703797