

UE ST- Base 500 STD

Item Code : PFPFBA001222

The UE ST-Base 500 is very powerful and equipped with our traditional professional base that allow using on the ground, elevated foot, shoot tower or hang under a structure. It is also suitable for service companies and for fixed installations designed to operate inside and outside. ST-Power Base 500 STD include speed variation and is equipped with professional connectors and a resettable fuse.

NOMENCLATURE :

- 1 x UE ST- Base 500 STD
- 5 x Tightenig buttons for heads
- 1 x PowerCon cable 5m



TECHNICAL SPECIFICATIONS :

Size : Lg 56 x lg 79 x Hg 79 cm - Weight: 38 Kg

Electrical Characteristics :
230V – 50/60Hz – 1500W – 6.5A – IP 55

Comply with norm CE ERP 2015

CHARACTERISTICS :

- Sound 91 dB / 3m inside.
- Sound 81 dB / 3m outside.
- Standard base ground.
- Ajustment on 110° vertical.
- Can be hung under structure.
- Electronic speed variation integrated in the base.
- Base control + Head for manual Switch.

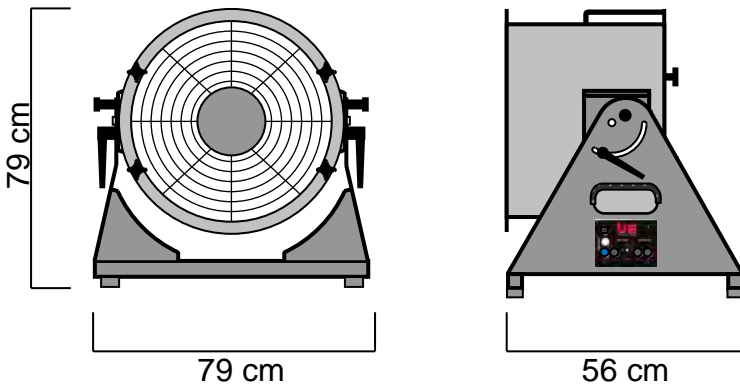

USABLE HEADS:

- | | |
|-----------------------|-------------------------|
| UE Head Foam 500 | UE Head Jet-Foam 500 |
| UE Head Snow 500 | UE Head Mist&Rain 500 |
| UE Head Twin 500 | UE Head Wind 500 |
| UE Head Fragances 500 | UE Head Jet-Bubbles 500 |
| UE Head AirFlame 500 | UE Head Projection 500 |

OPTIONAL ACCESSORIES :

- UE Skate Board 500
- UE Feet 50, 70, 100 (x 4)
- UE Shoot Tower 500

Manufactured in ALUMINIUM and STAINLESS, UE ST-Base 500 STD is done for last. Each element was chosen for his quality and efficiency.

Universal Effects, La qualité et l'innovation Fabriqué en France



TECHNICAL DATASHEET

UE Head Mist & Rain 500

Item Code : PFPFRA001214

The UE Head Mist and Rain allows you to create your own weather. To refresh the mood, project water in mist mode. When you need to create a well-watered scene with wind, switch to rain mode. Effect used in cinema, video production and theme park. Delivered complete with its pump on support and all necessary hoses.

NOMENCLATURE :

- 1 x UE Head Mist & Rain 500
- 1 x Pump 500
- 1 x Hose Kit

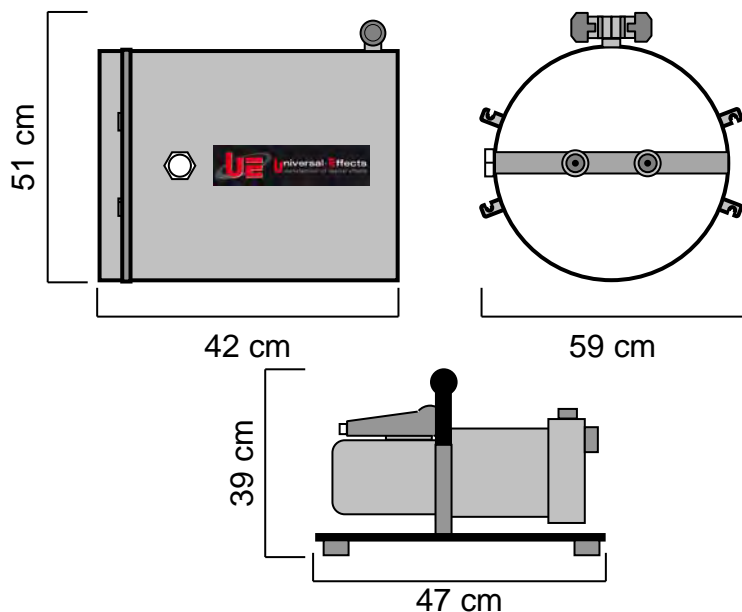

TECHNICAL SPECIFICATIONS :

Size : 42 x 59 x 51 cm
Weight : 32.8 Kg

NECESSARY ACCESSORIES:

Pump 500: Size : 47 x 34 x 39 cm
 Weight : 17,4 Kg
 Electrical Specifications :
 230V – 50Hz – 1300W – 6,1A

Hose Kit : Length : 5 m and 7 m
 Weight : 5,6 kg

BASES USABLE :

- UE ST- Base 500
- UE XT- Base 500

CONSUMPTION :

- On EU ST / XT- Base 500 mist cloud projection at 10m.
- Water consumption with mist nozzle: 6L / mn
- On EU ST / XT- Base 500 rain projection at 10m.
- Water consumption with 2 rain nozzles: 74L / mn

CONSUMABLE :

water (provide storage barrel).

Universal Effects, La qualité et l'innovation Fabriqué en France

Universal Effects est une Marque fabriquée et distribuée par la société Premium Factory SAS
1 Route Neuve, 71710 MONTCENIS - FRANCE | Email info@premiumfactory.eu | www.premiumfactory.eu
Société Anonyme Simplifié au capital de 1 000 € | Siret 840 703 797 00018 | VAT Nr: FR47840703797