

TECHNICAL DIAGRAM – UE ST- BASE 350 & 500

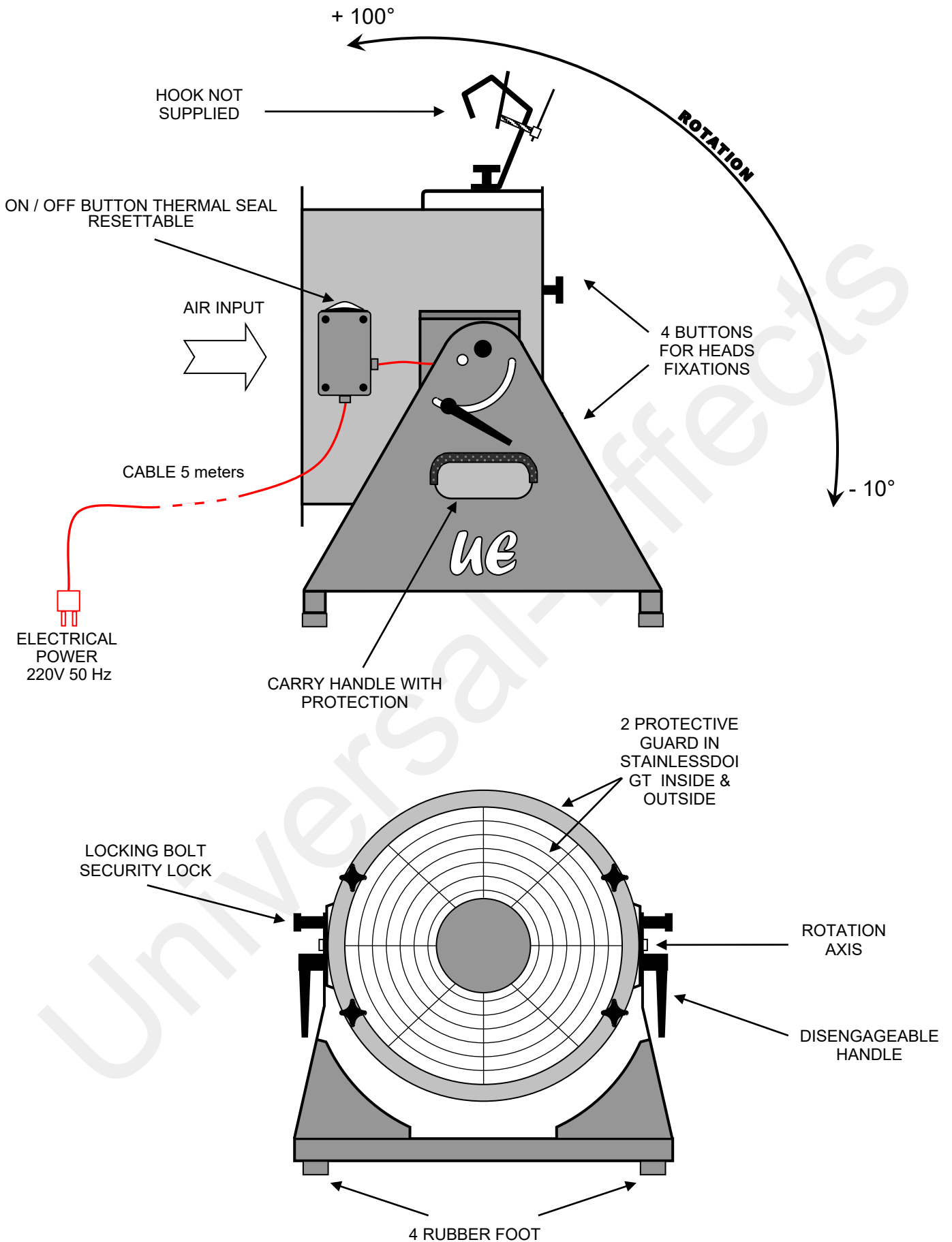

SCREWS AND HARDWARE IN STAINLESS – ALUMINIUM BODY – VERY POWERFUL

TECHNICAL DIAGRAM – UE ST- BASE 350 & 500 WITH 4 POSSIBLES OPTIONS

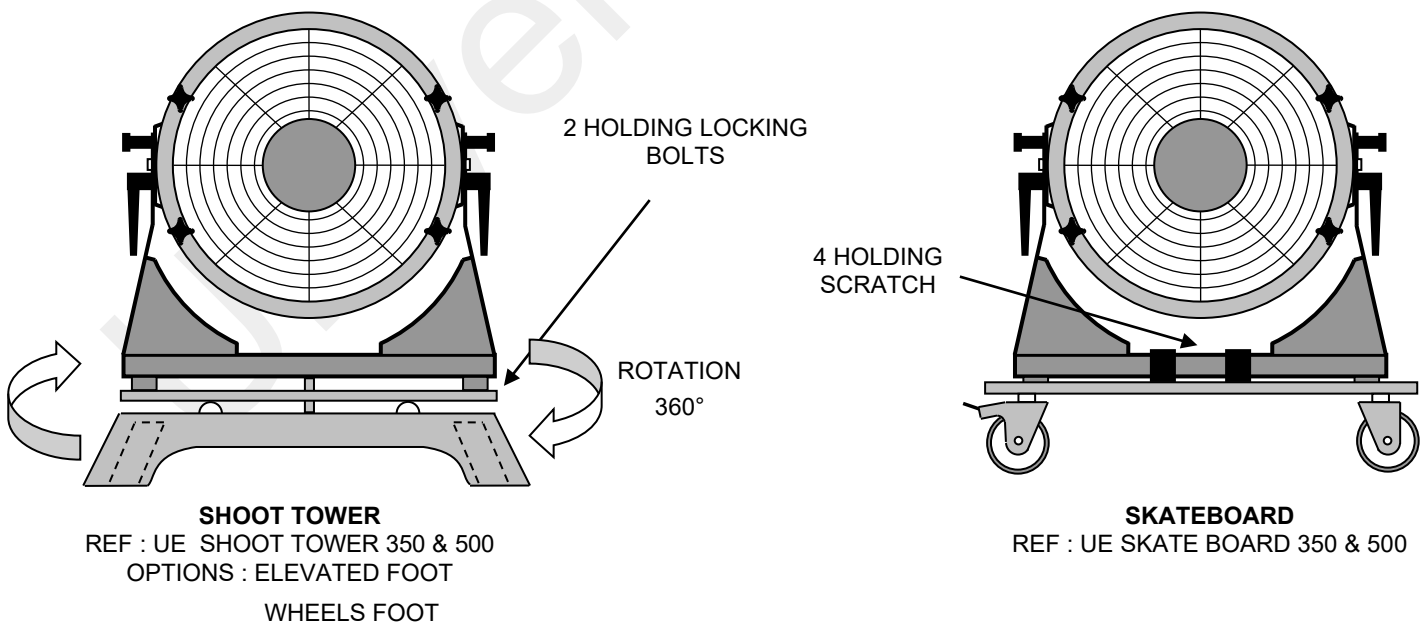
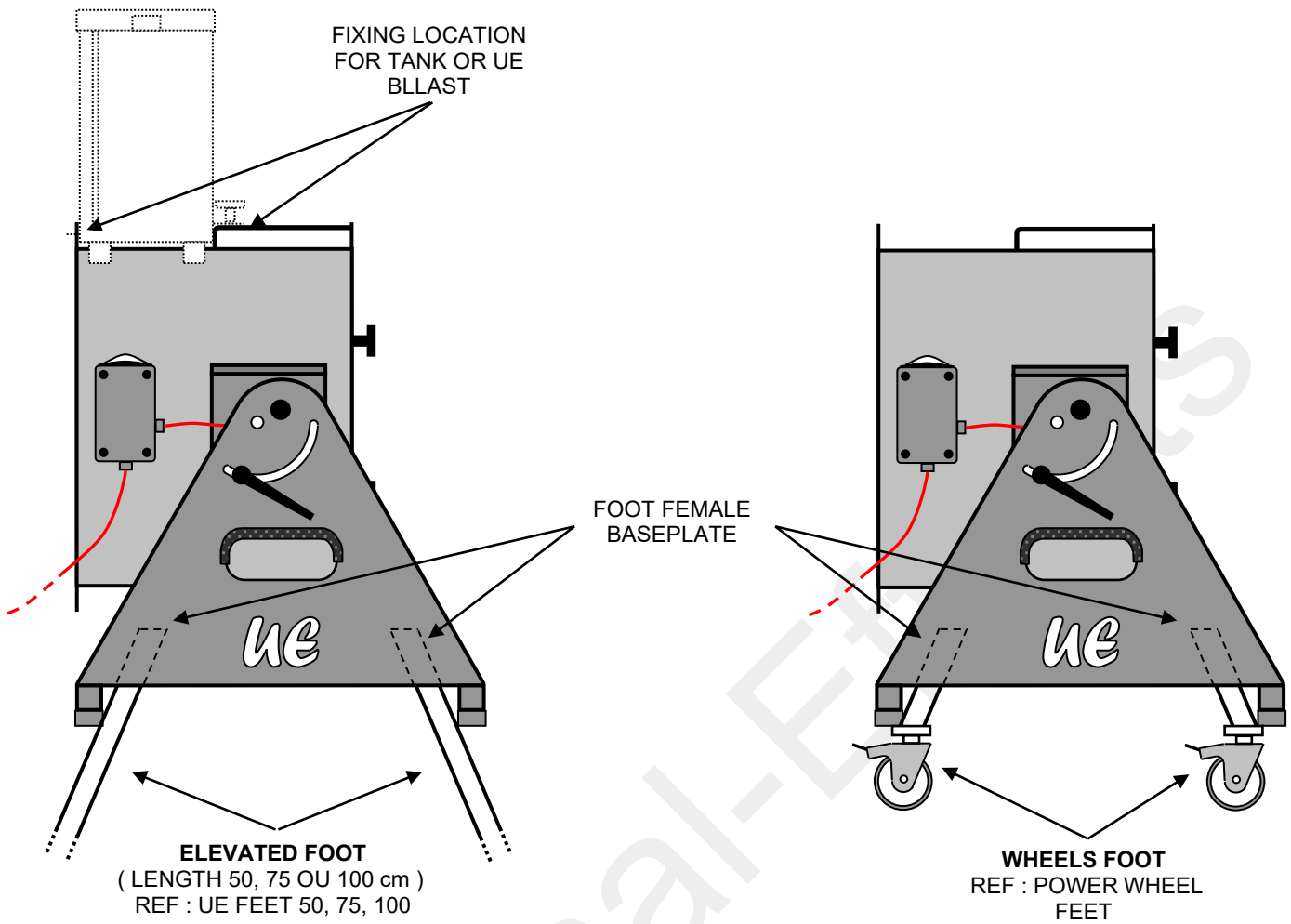

SCREWS AND HARDWARE IN STAINLESS – ALUMINIUM BODY – VERY POWERFUL

COMBINATIONS WITH UE ST- BASE 350 & 500

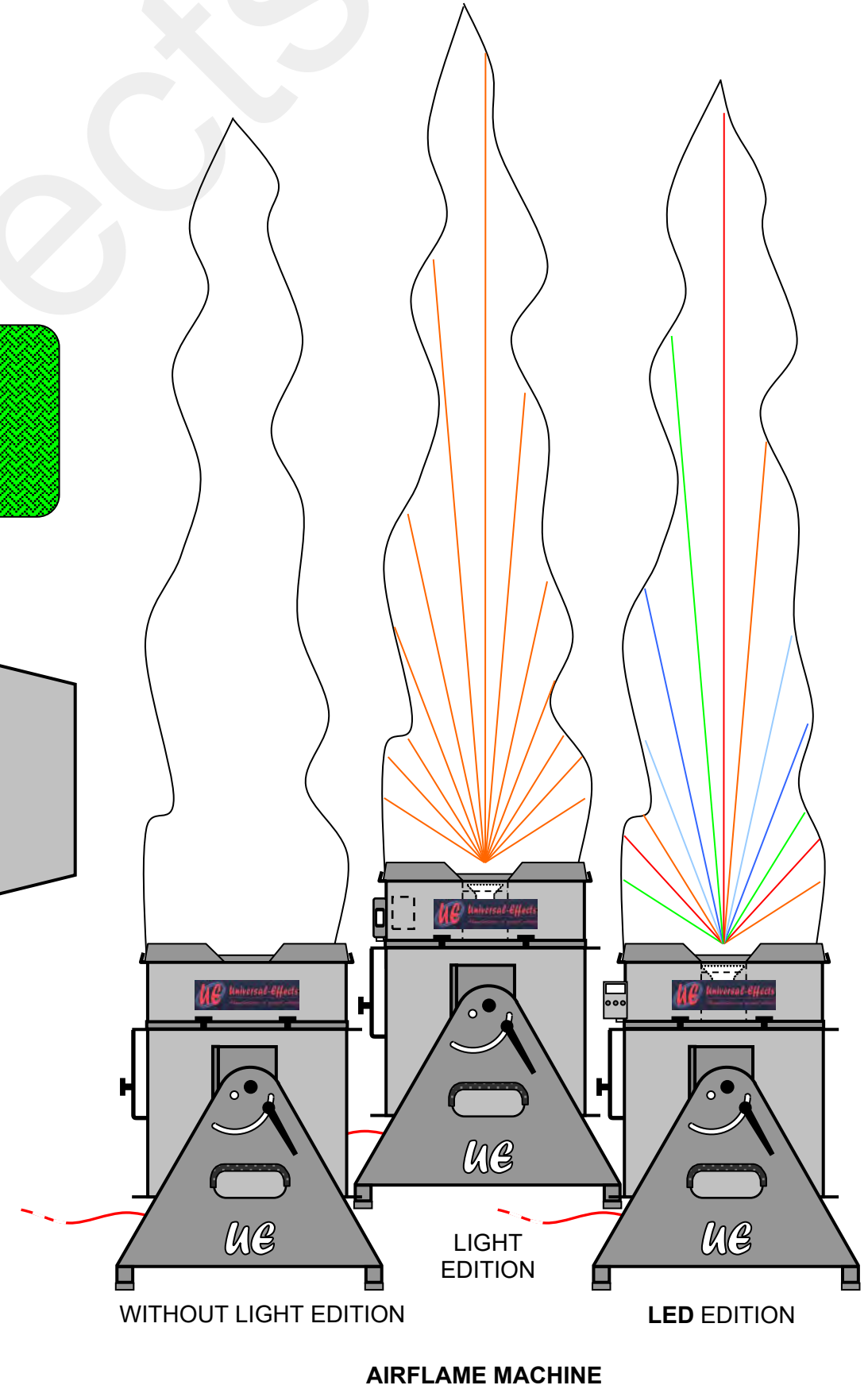
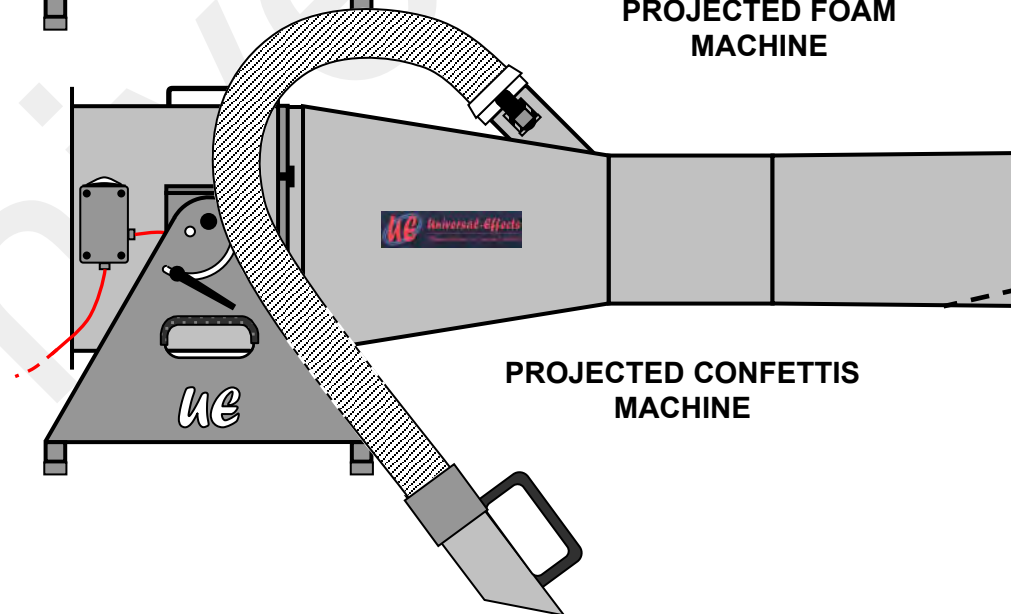
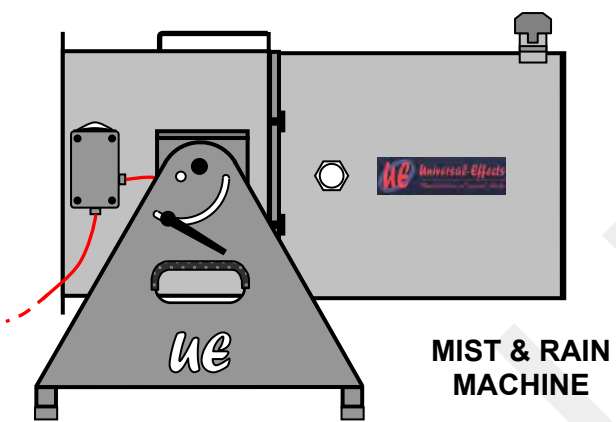
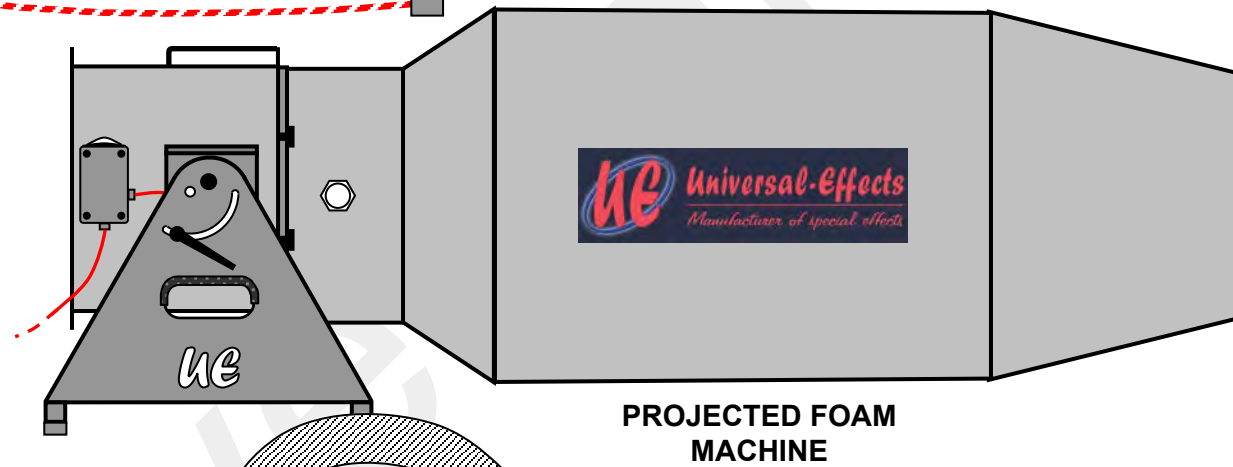
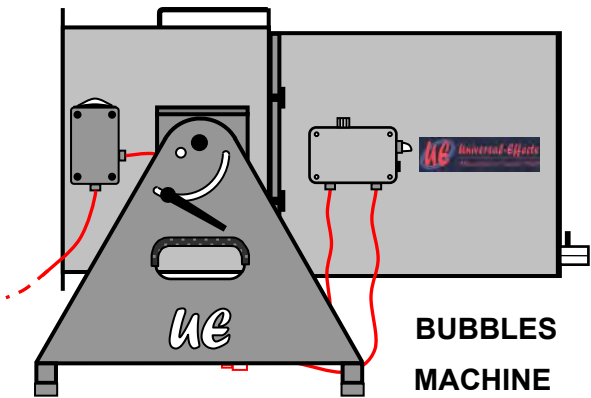
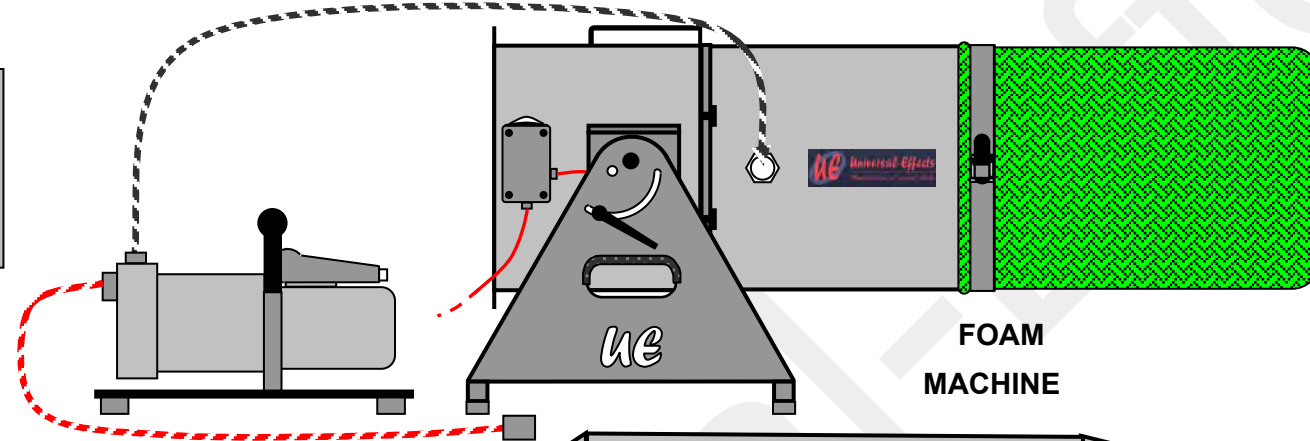
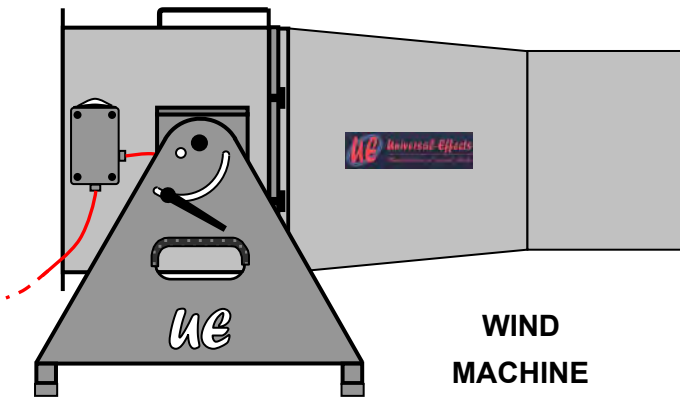
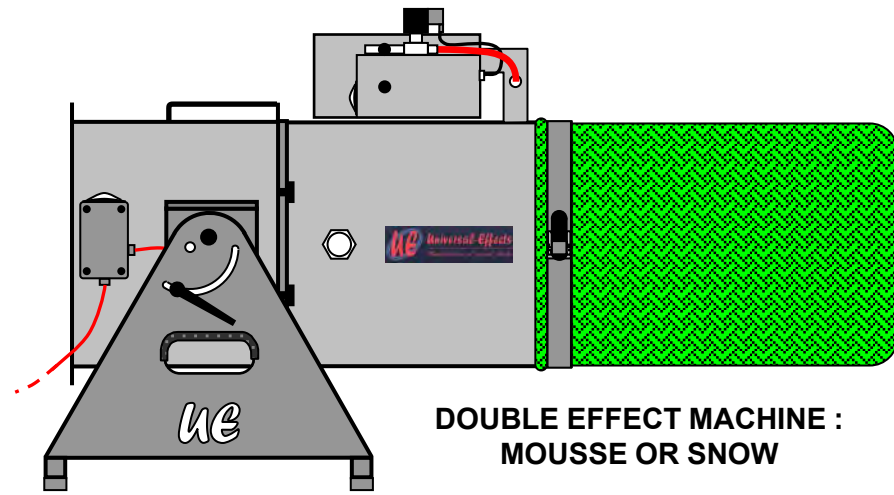
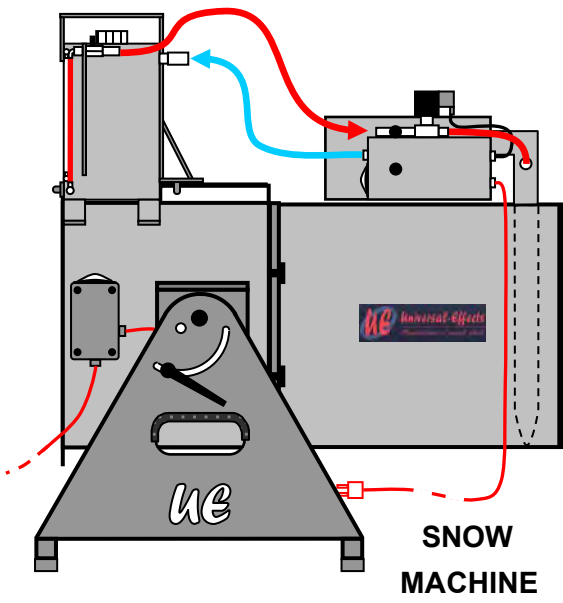

TECHNICAL DIAGRAM – UE HEAD SNOW

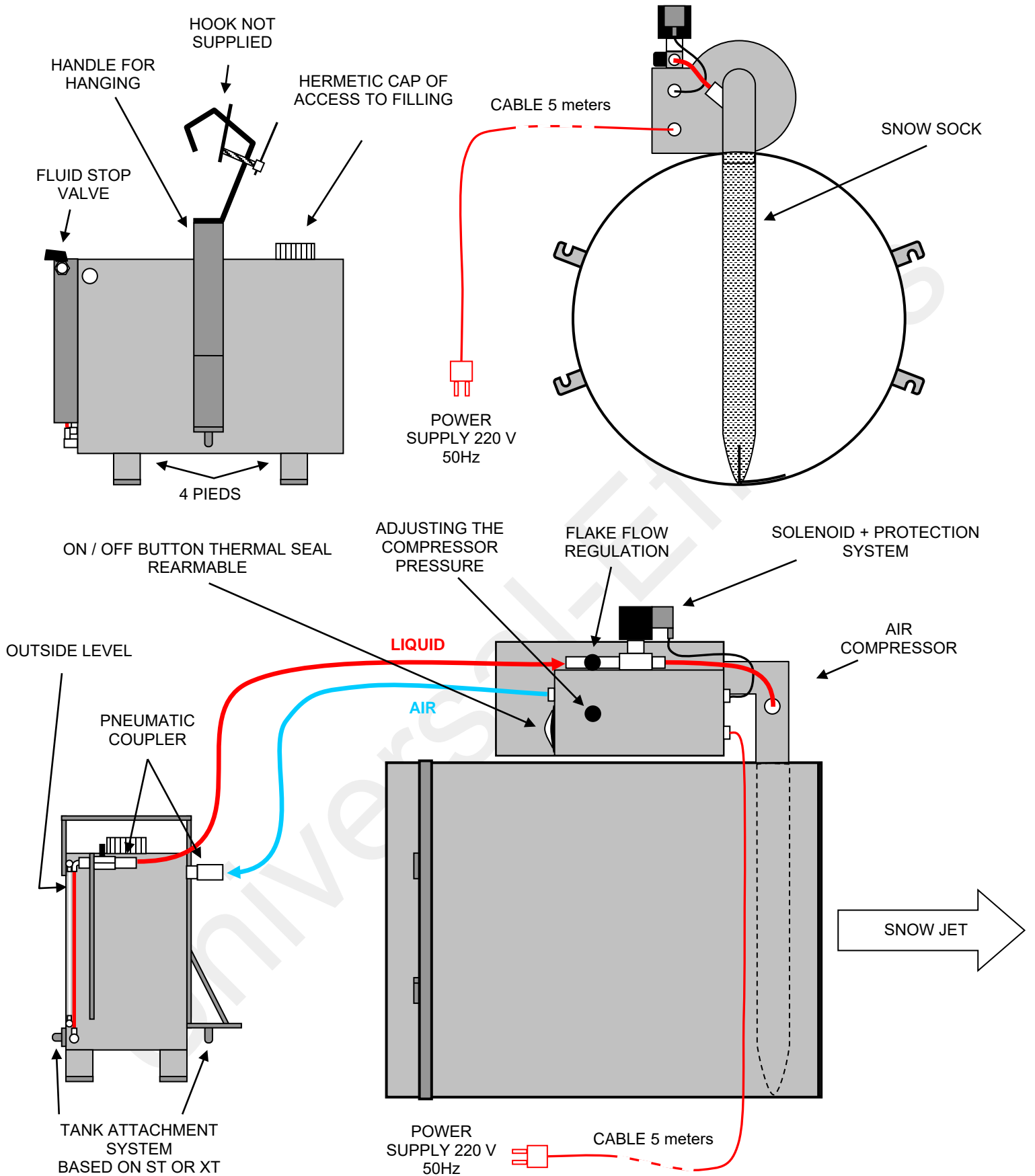

STAINLESS SCREWS & HARDWARE - ALUMINUM BODY



Kit Connection Snow Fluid Tank For Snow Tube

1st Option

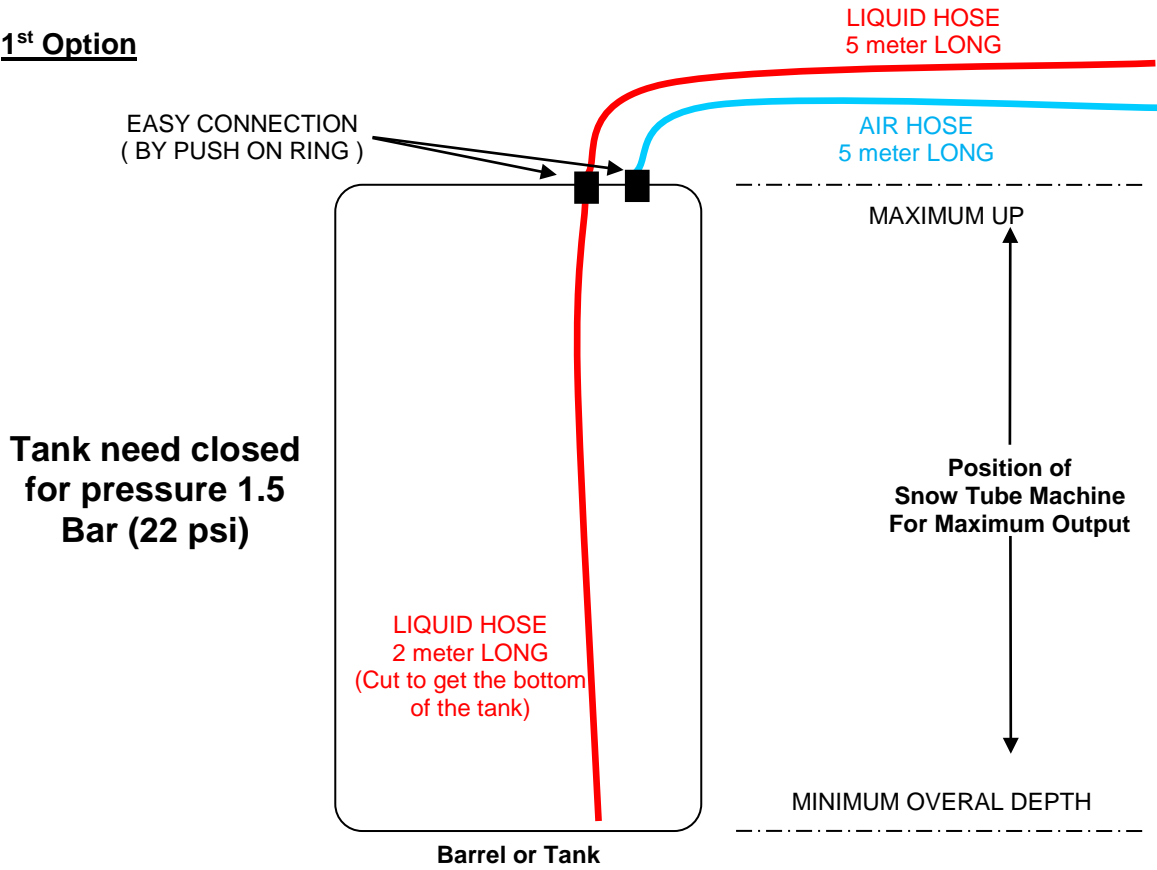

2nd Option

