

# SCHEMA TECHNIQUE – UE ST- BASE 350 & 500

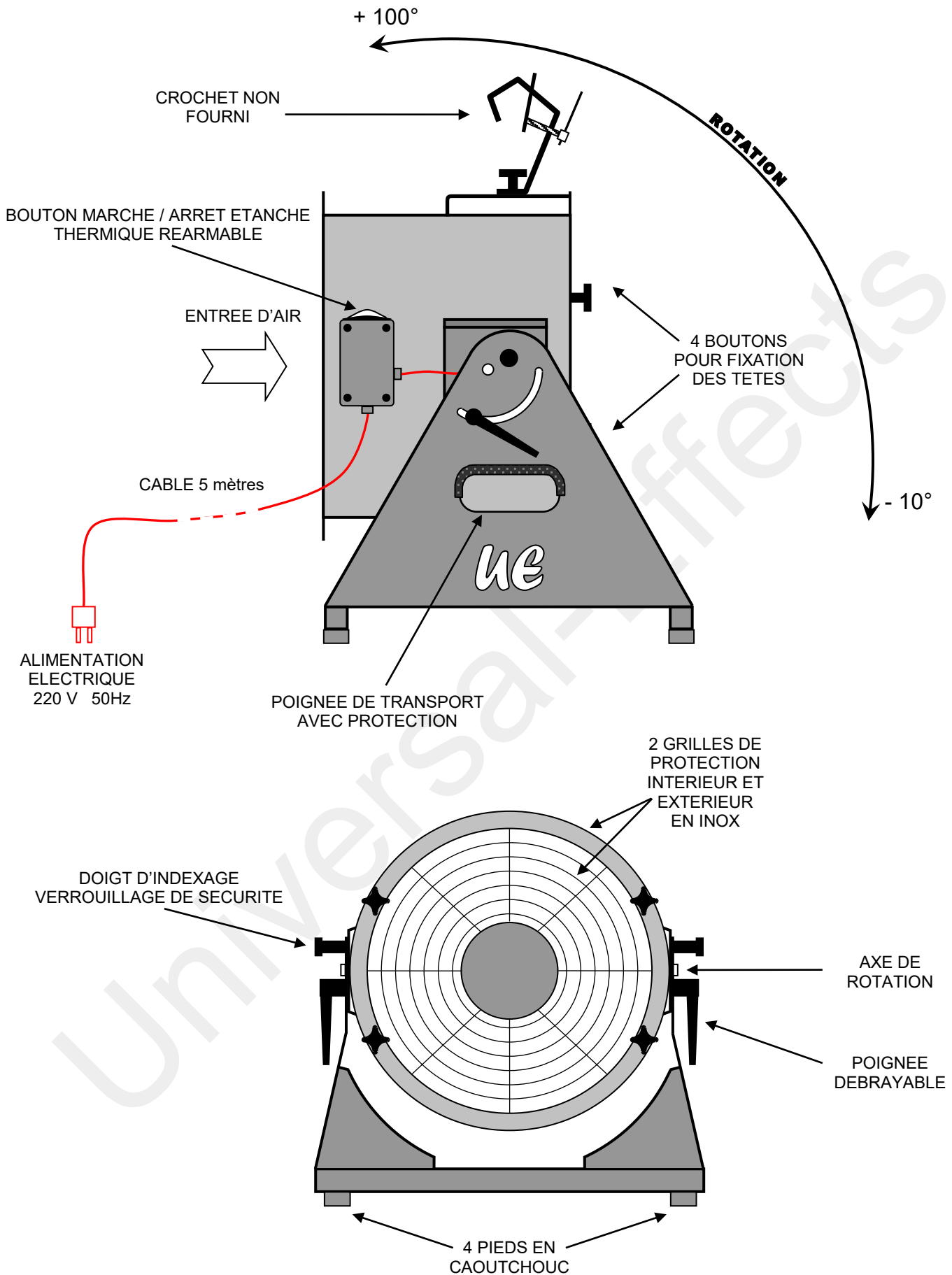

VISSERIE & QUINCAILLERIE EN INOX – CORPS EN ALUMINIUM – TRES PUISSANT

# SCHEMA TECHNIQUE – UE ST- BASE 350 & 500 AVEC 4 OPTIONS POSSIBLES

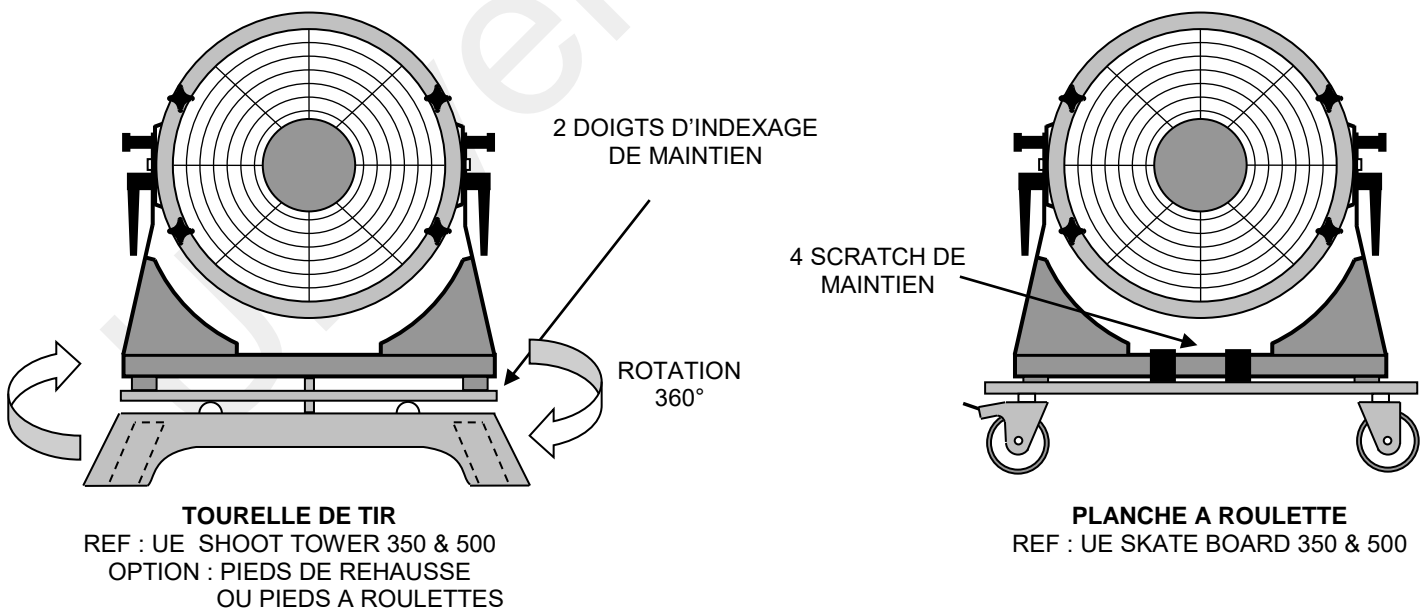
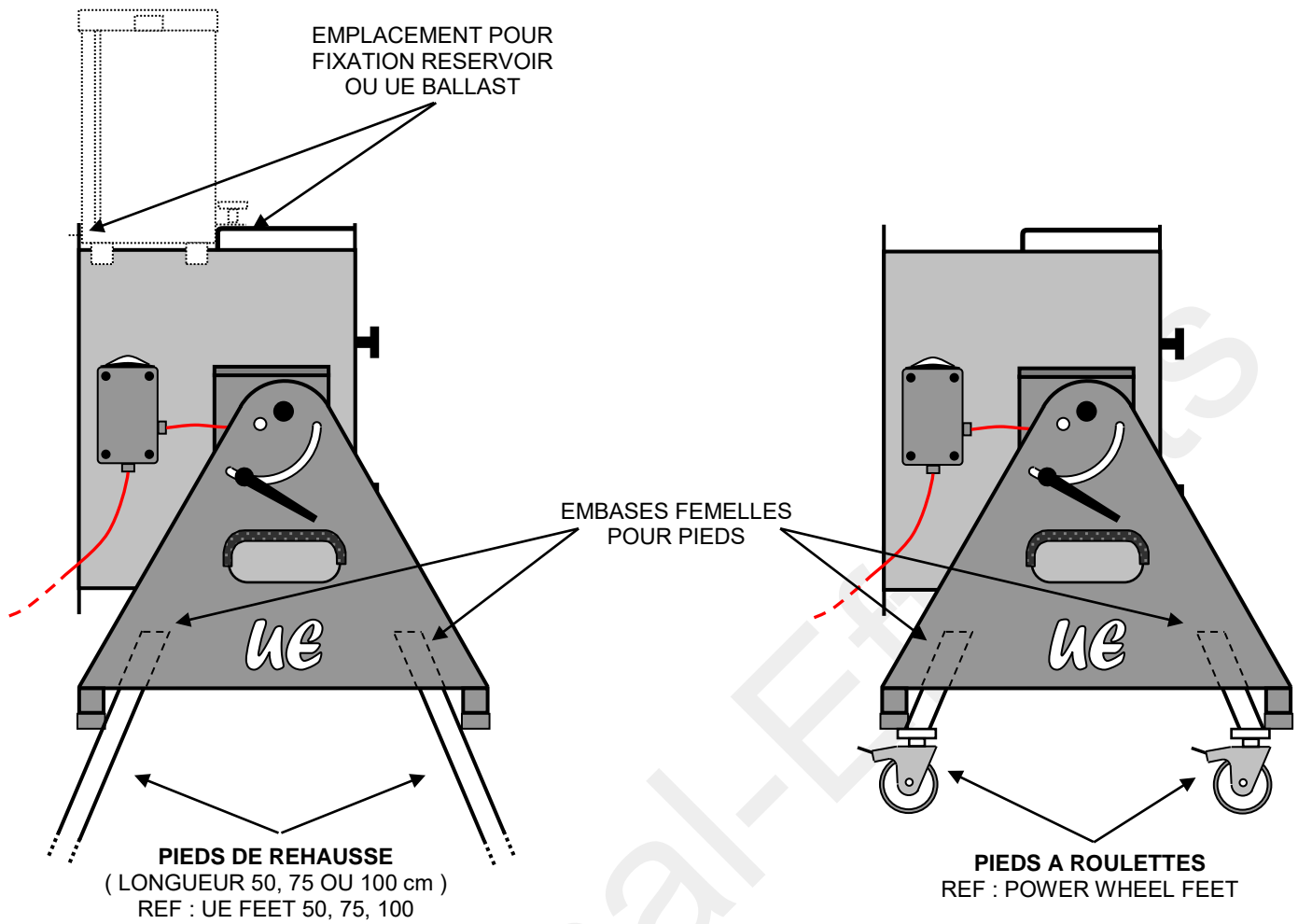

VISSERIE & QUINCAILLERIE EN INOX – CORPS EN ALUMINIUM – TRES PUISSANT

# LES COMBINAISONS AVEC UE ST- BASE 350 & 500

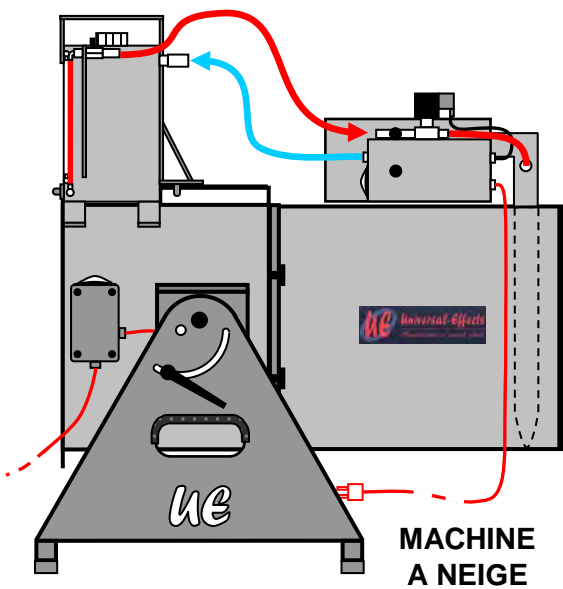

MACHINE A NEIGE

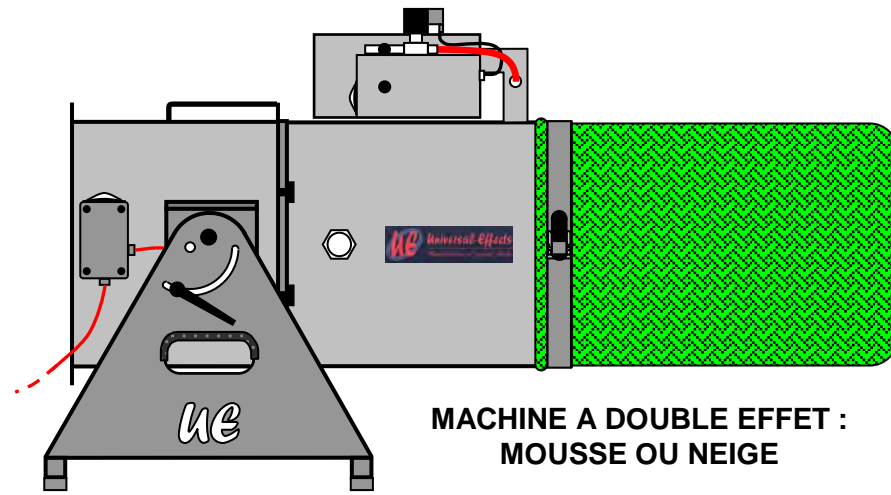

MACHINE A DOUBLE EFFET : MOUSSE OU NEIGE

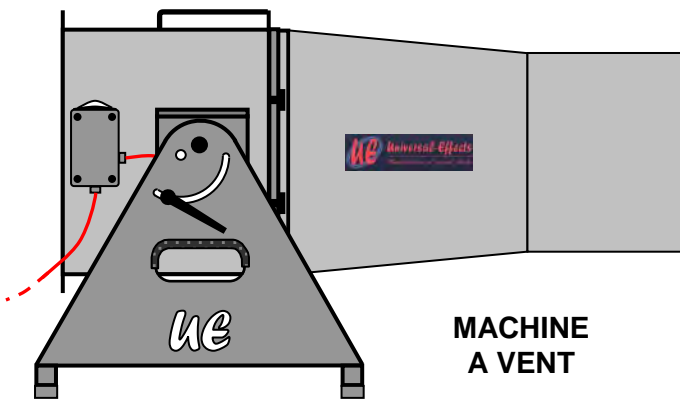

MACHINE A VENT

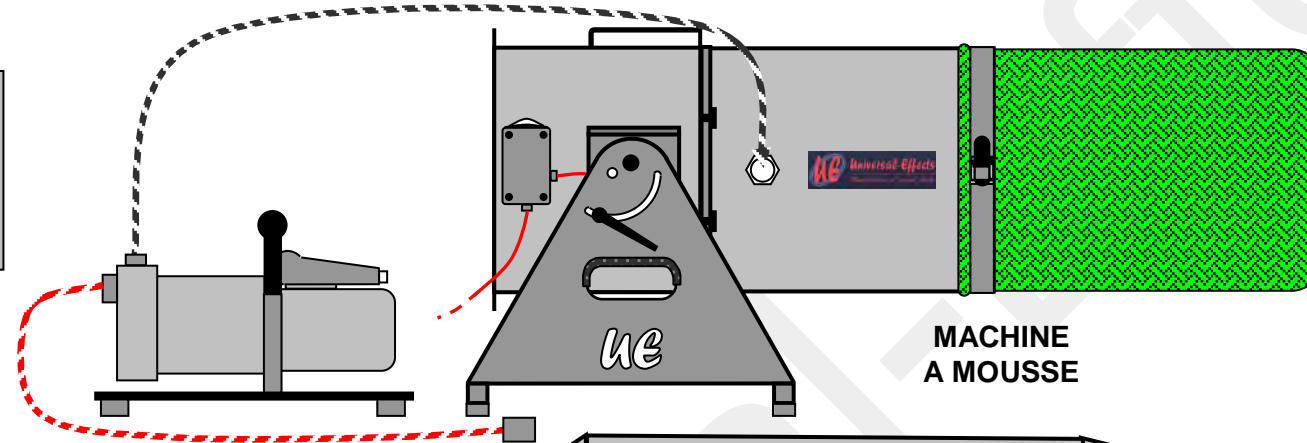

MACHINE A MOUSSE

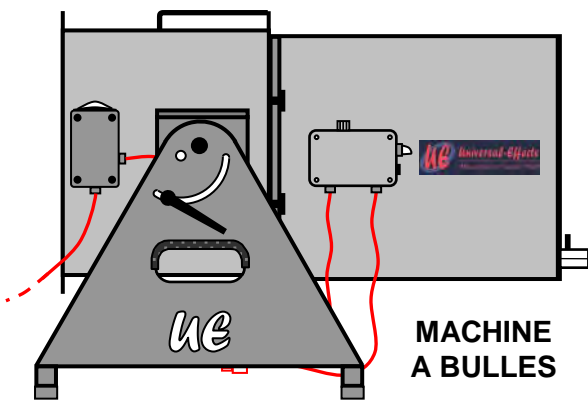

MACHINE A BULLES

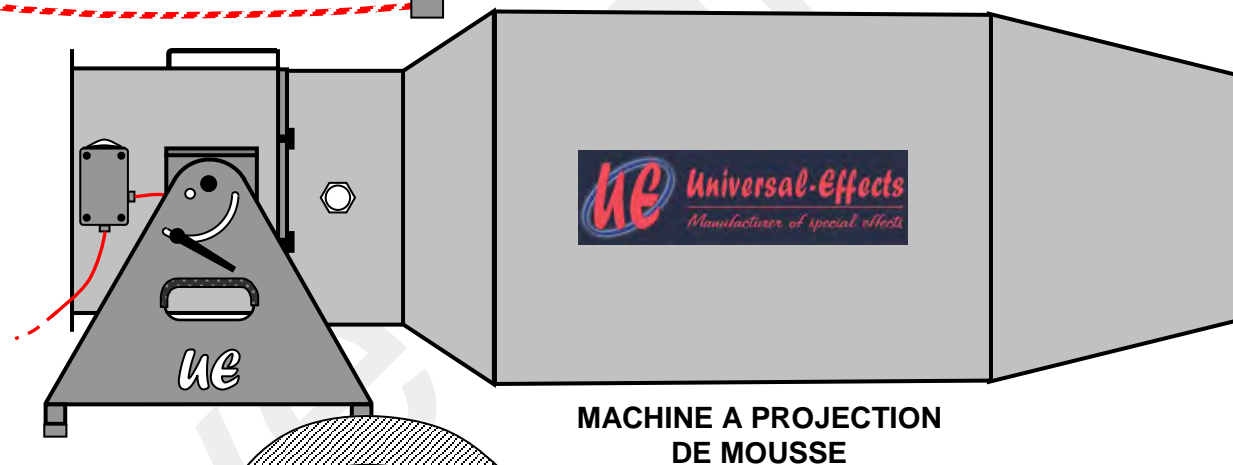

MACHINE A PROJECTION DE MOUSSE

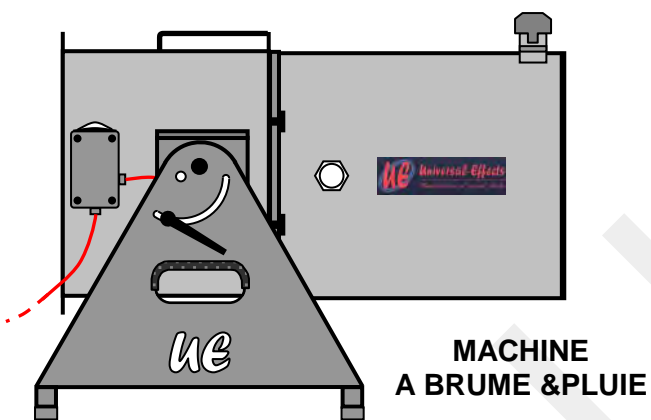

MACHINE A BRUME & PLUIE

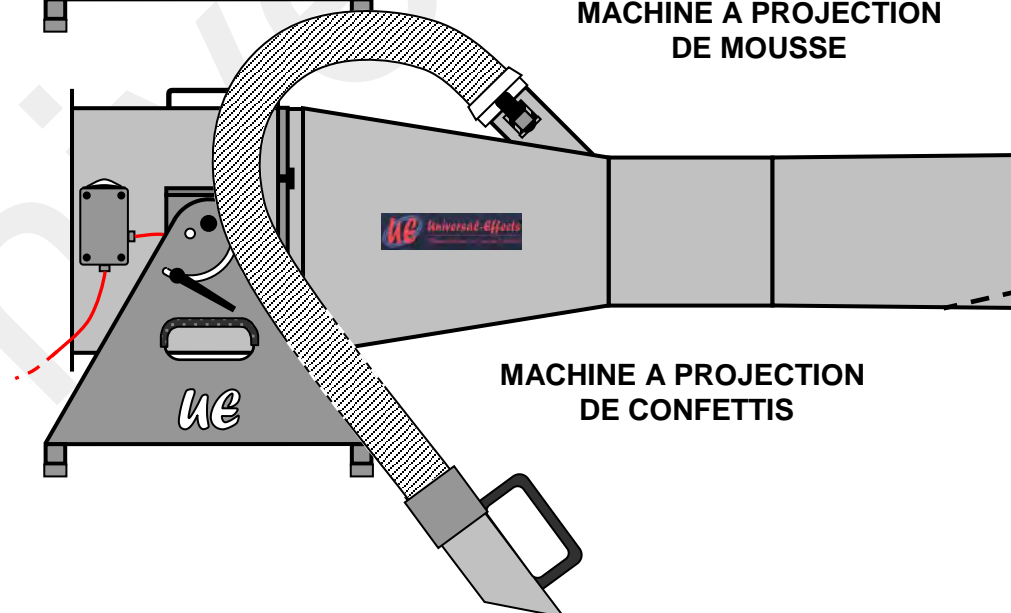

MACHINE A PROJECTION DE CONFETTIS

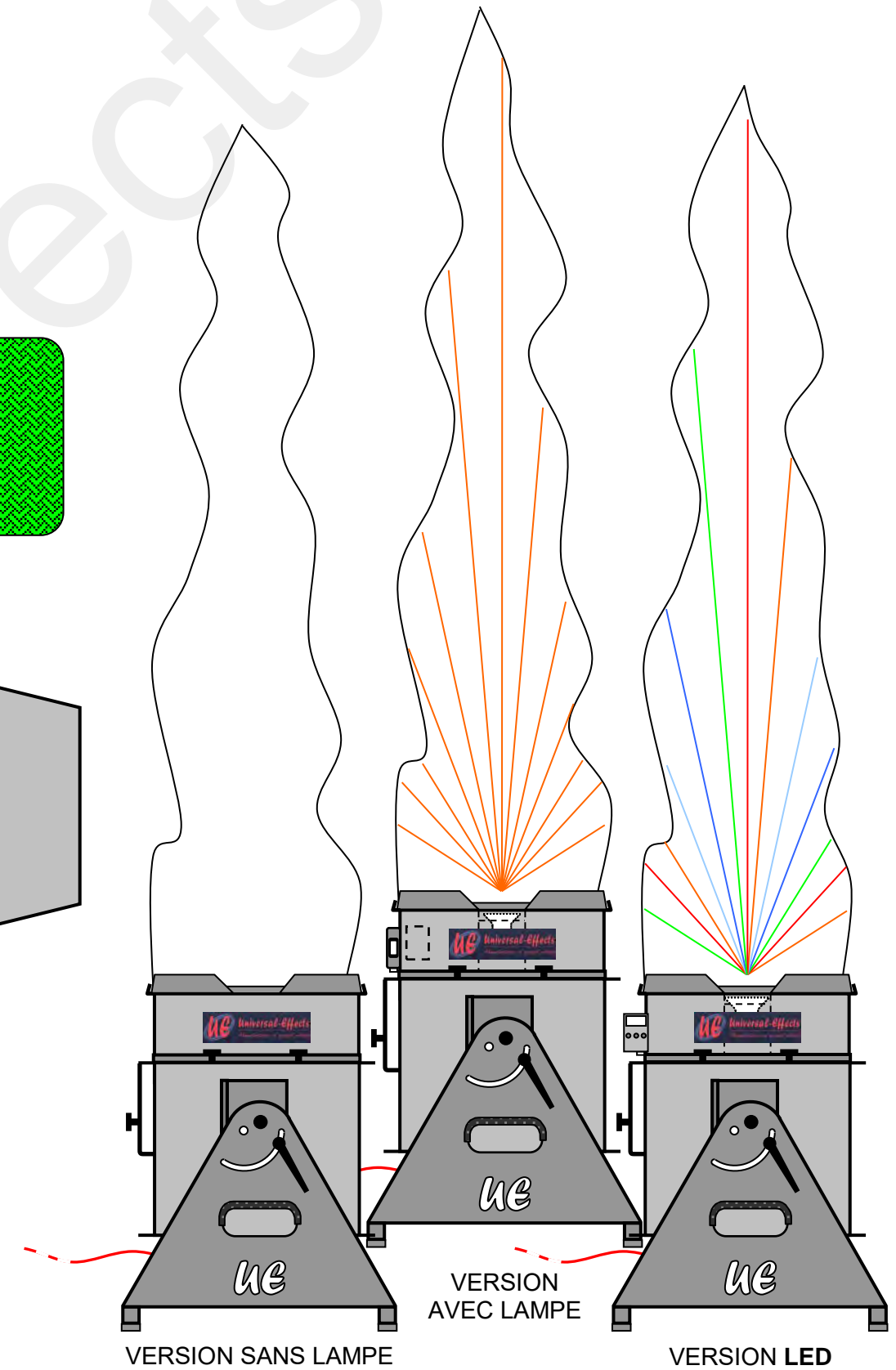

VERSION SANS LAMPE

VERSION AVEC LAMPE

VERSION LED

MACHINE A FLAMME DE SOIE

# SCHEMA TECHNIQUE – UE HEAD WIND

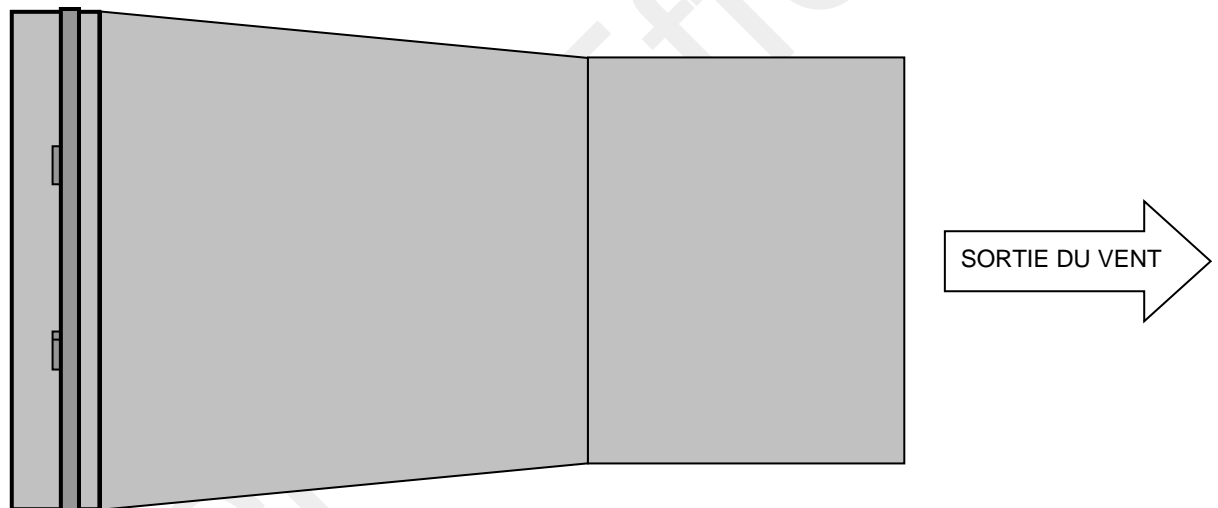

- VENT DIRIGE ET ACCELERE
- PERMET UNE PRECISION ET UNE PORTEE IMPORTANTE
- CORPS EN ALUMINIUM

# TECHNICAL DIAGRAM – UE ST- BASE 350 & 500

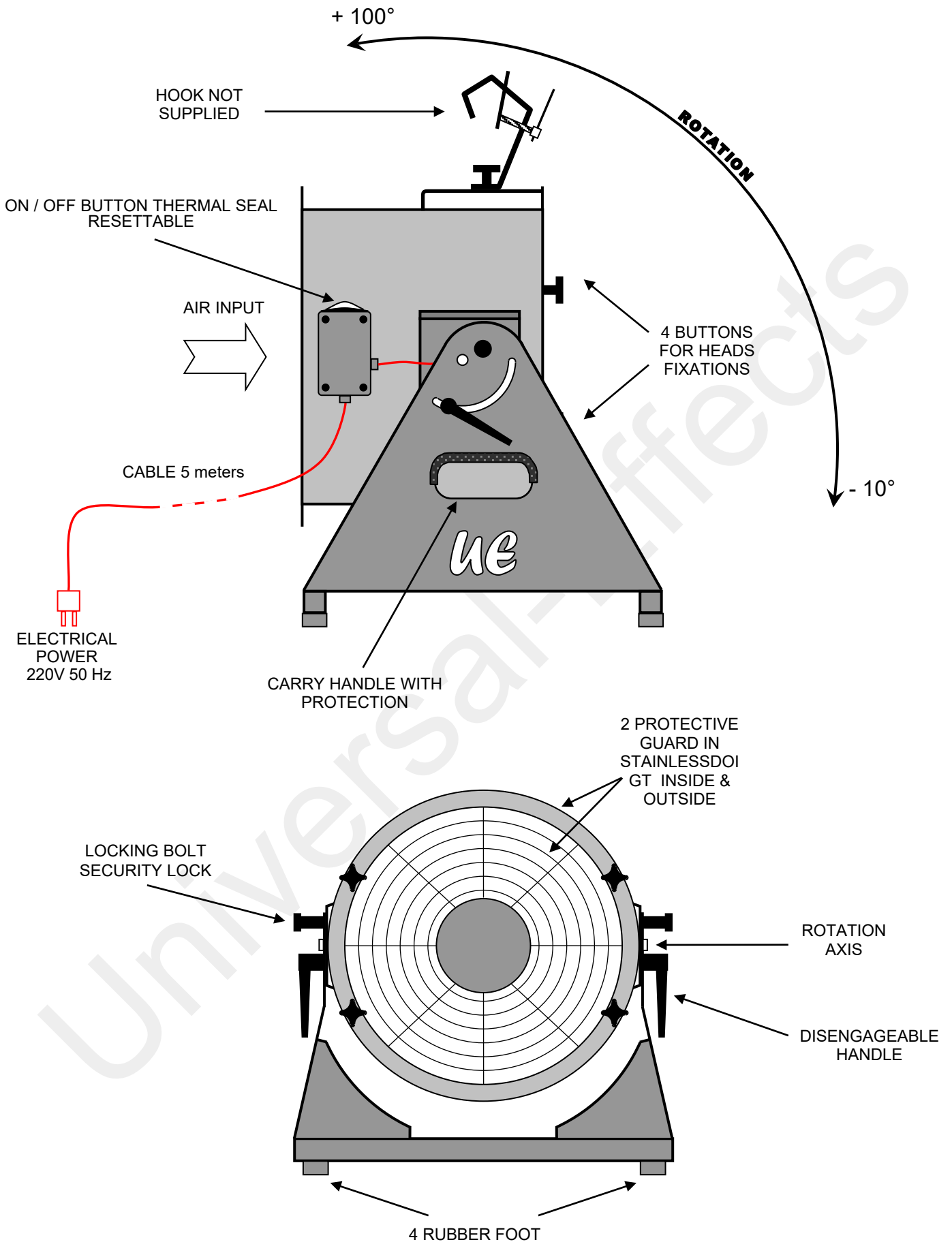

SCREWS AND HARDWARE IN STAINLESS – ALUMINIUM BODY – VERY POWERFUL

# TECHNICAL DIAGRAM – UE ST- BASE 350 & 500 WITH 4 POSSIBLES OPTIONS

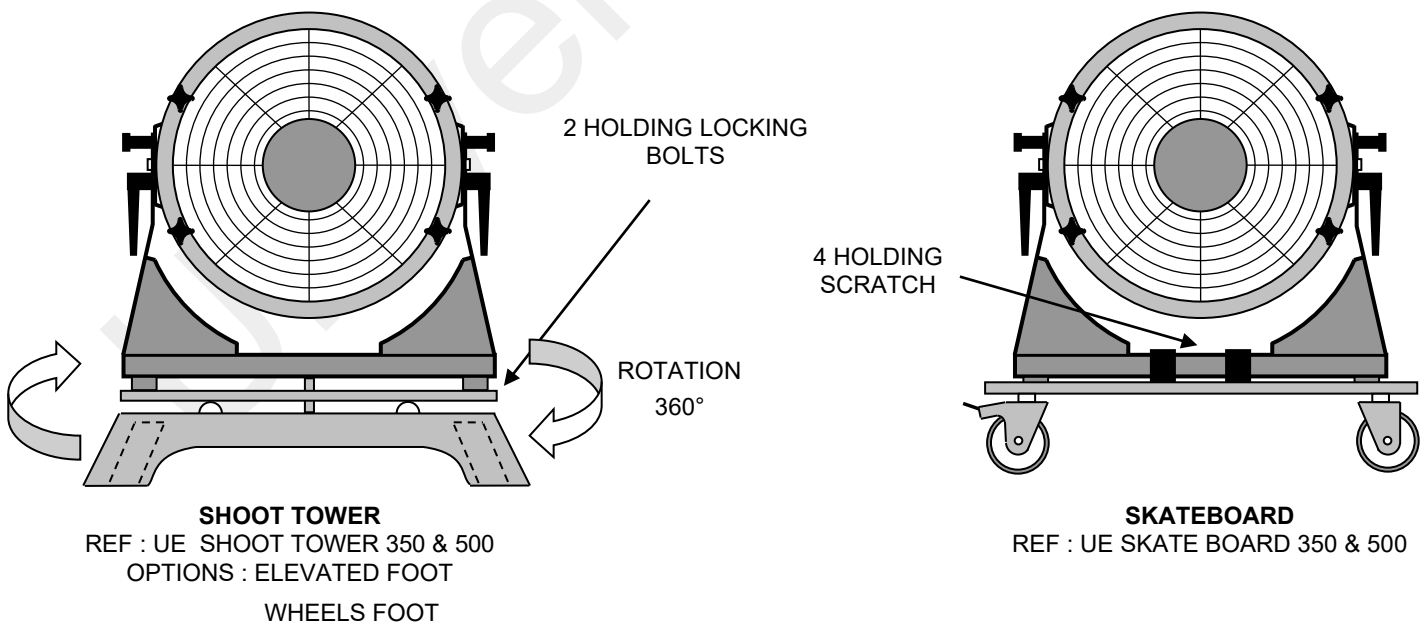
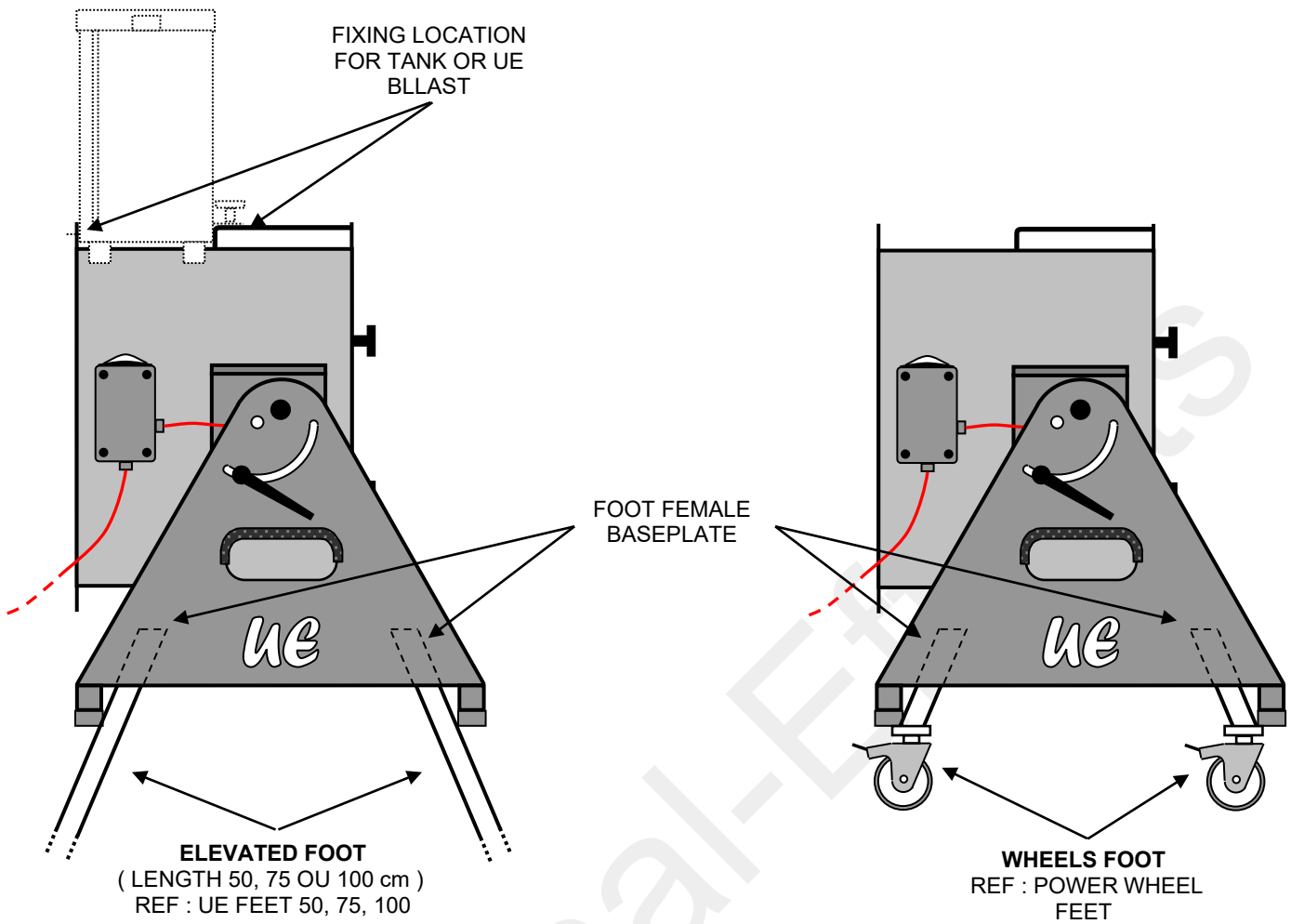

SCREWS AND HARDWARE IN STAINLESS – ALUMINIUM BODY – VERY POWERFUL

# COMBINATIONS WITH UE ST- BASE 350 & 500

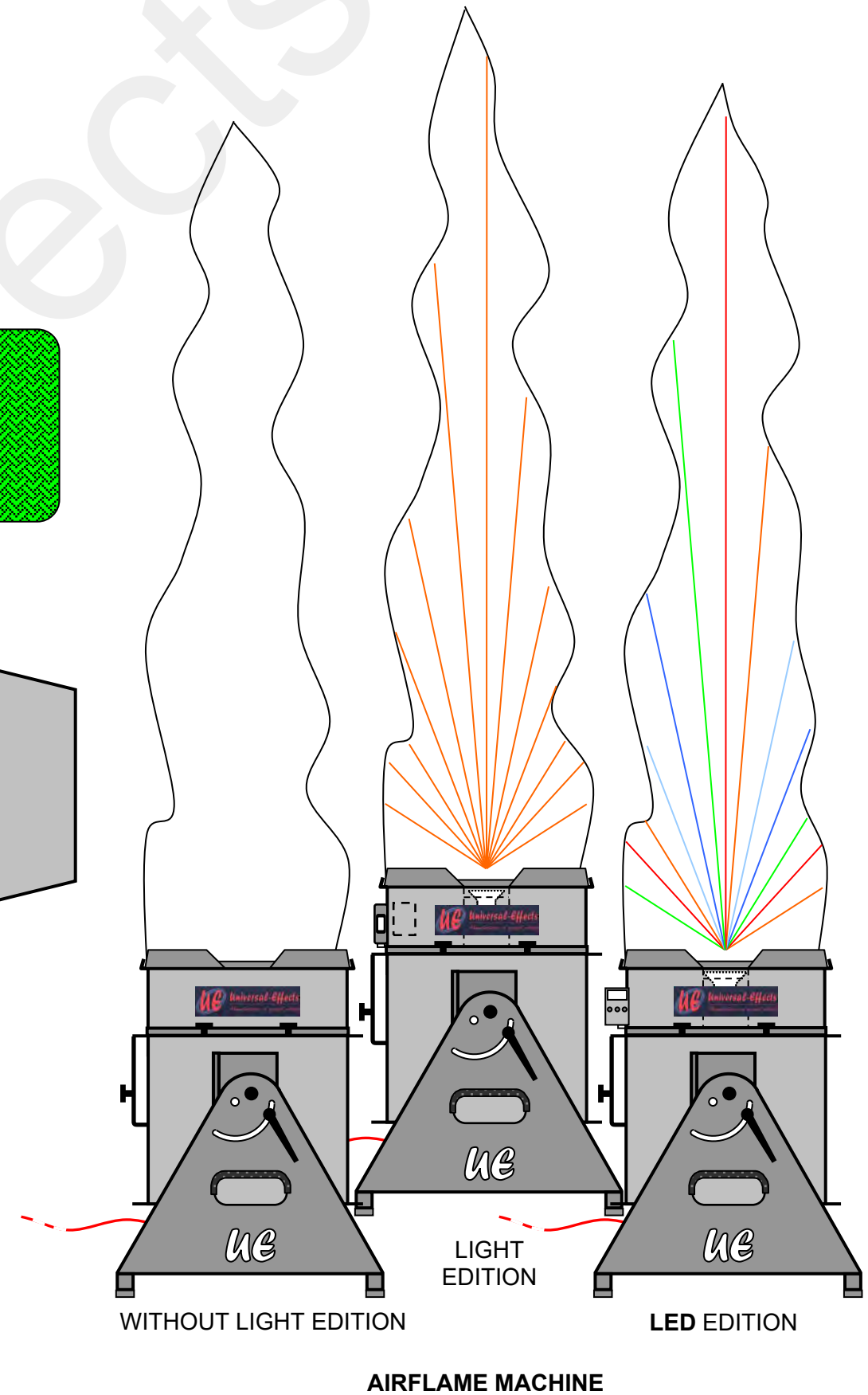
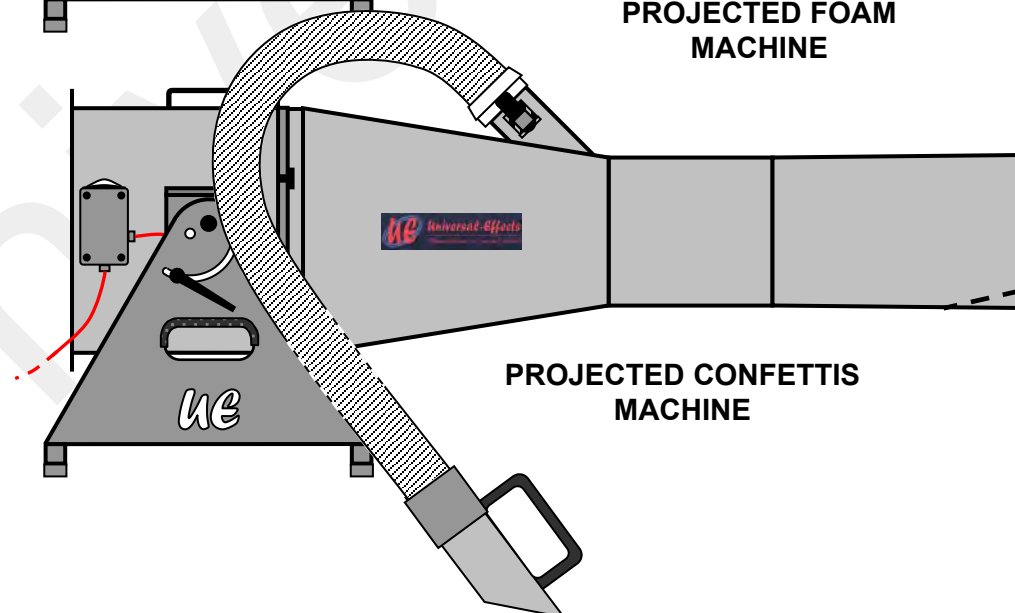
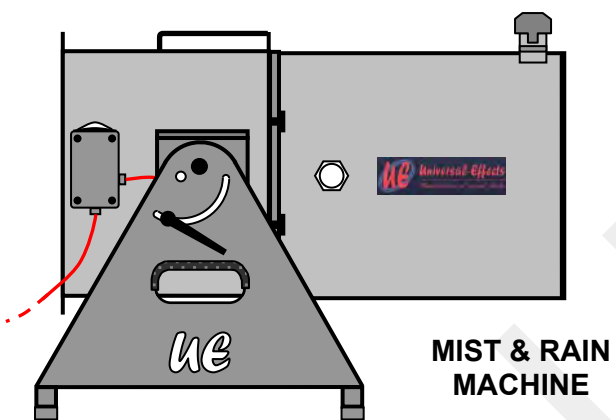
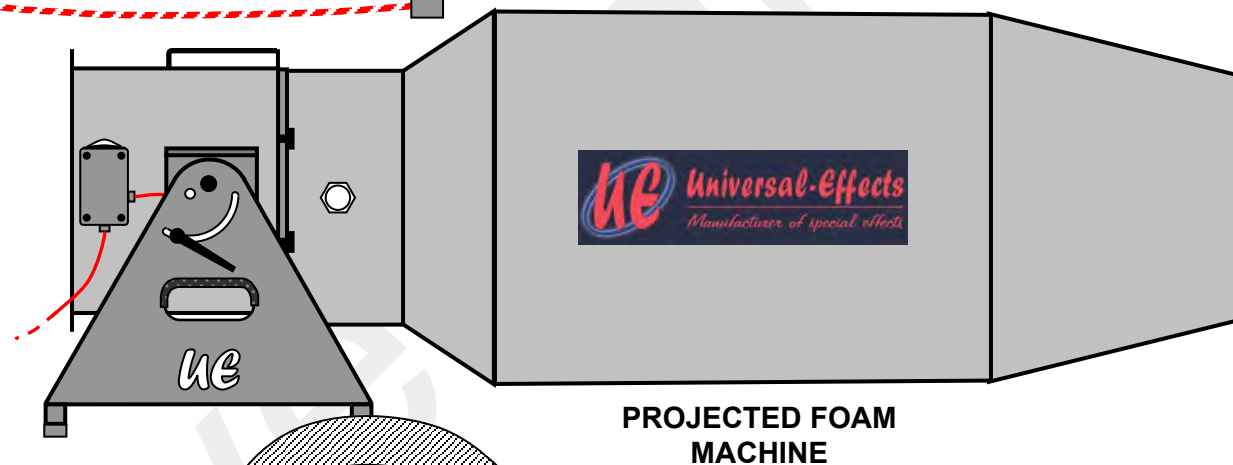
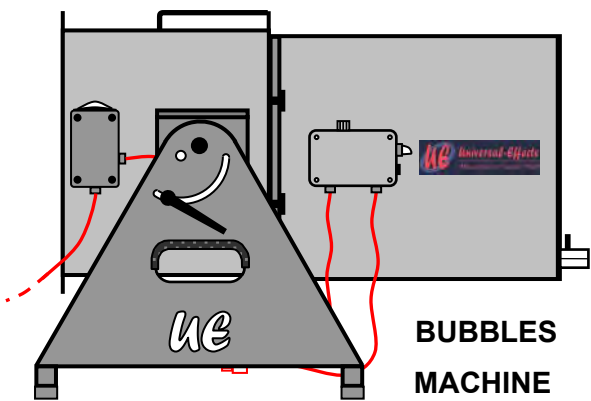
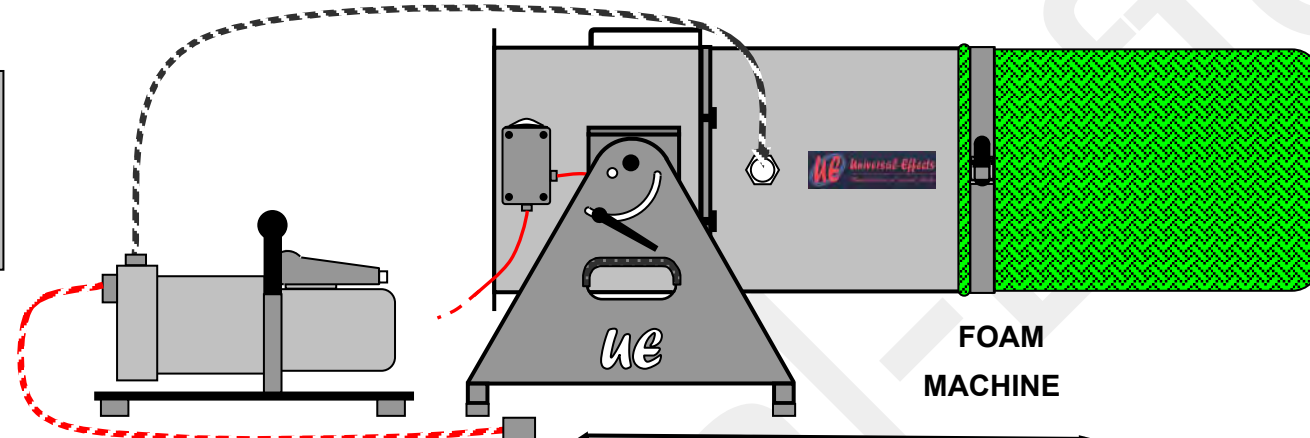
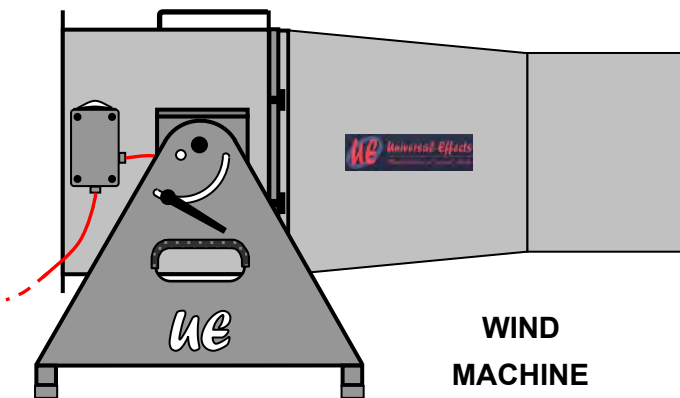
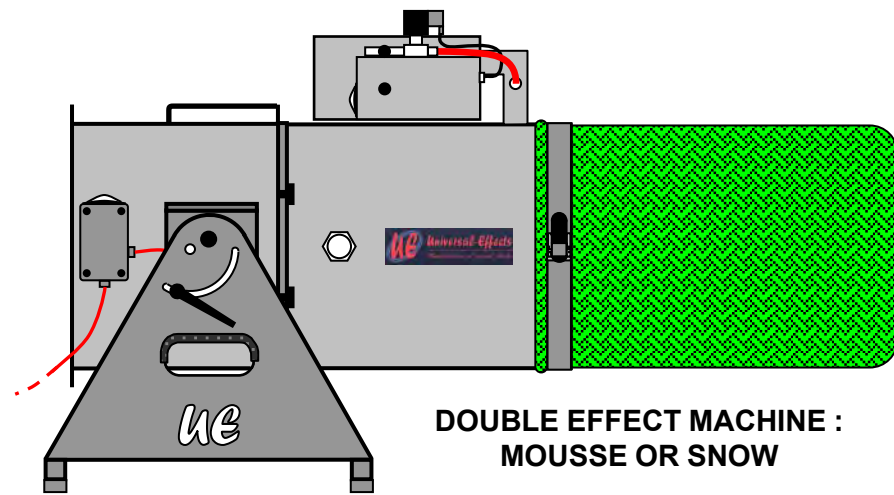
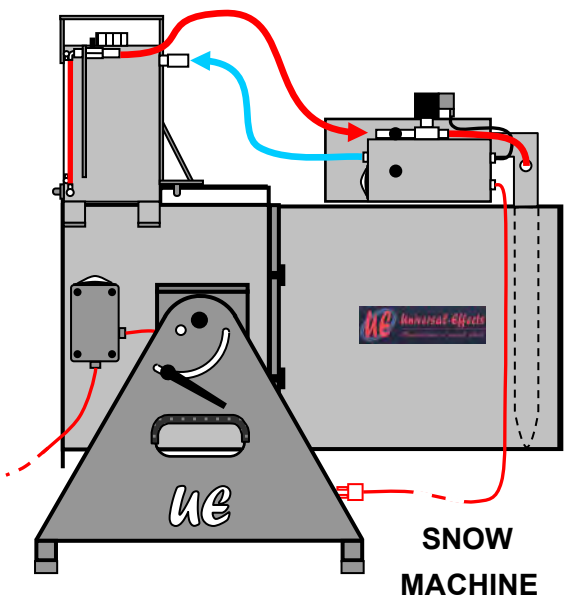

# TECHNICAL DIAGRAM– UE HEAD WIND

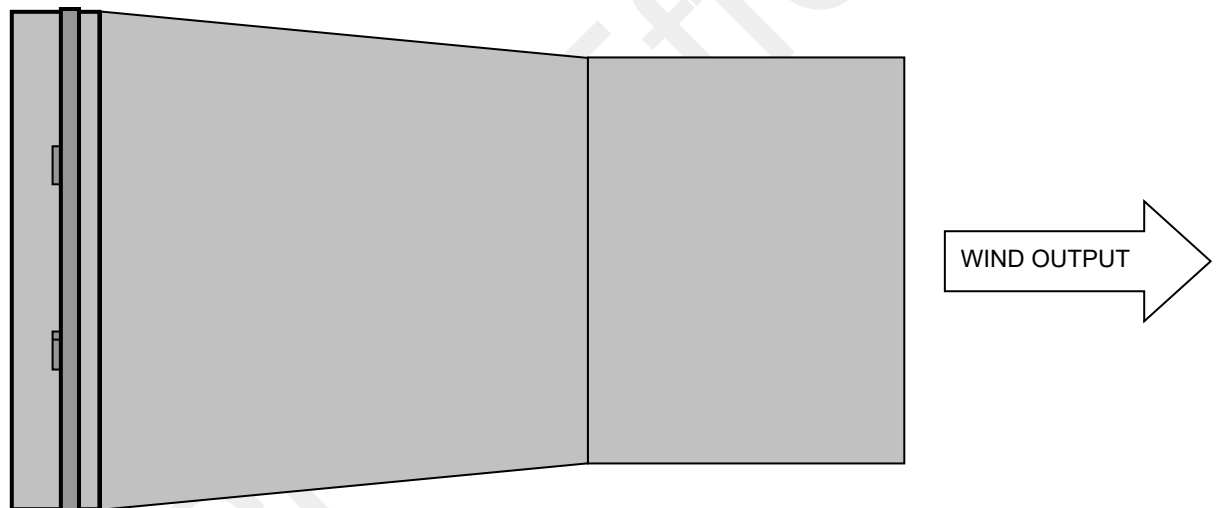

- GUIDED AND ACCELERATED WIND
- ALLOWS AN IMPORTANT PRECISION AND SCOPE
- ALUMINIUM BODY