

USER MANUAL

uFlamer PF10 (DMX)

V1.0

2022.05

SHOWVEN[®]



SHOWVEN Technologies Co., Ltd

Thanks for choosing SHOWVEN uFlamer PF10, we wish it will bring you lots of exciting moments. Please read the following manual carefully before operating this product.

▲ Warning

- ∨ This product is only suitable for qualified or skilled operators who has experience with the technology of the device and is particularly informed about the types of fuel used by the device.
- ∨ Unauthorized repair are prohibited, it may cause serious incident.
- ∨ Make sure power supply in consistent with the rated voltage of the equipment, and the socket must well grounded. Unplug and turn off the machine when not use.
- ∨ Please connect DMX cable before turn on the power supply, and make sure communication command stay at non firing status.
- ∨ After turning on the device, no person allows to stay in the danger area. Ensure all persons that are part of the show be informed about the safety distance, risks and functions of the device.
- ∨ Always have a CO2 fire extinguisher and an extinguishing blanket in case of needed.
- ∨ If there be any doubt as to the safety operation of the device in any circumstances, the device should be taken out of service immediately. Be sure the device is in good operating condition before use. If fail to fire correctly, immediately shut down and check it accordingly. Any questions please always contact SHOWVEN (info@showven.cn) for help.
- ∨ Be sure to use high quality flame fluid, otherwise, it is easily leads to failure or danger. Be careful when refill the flame fluid tank. Please keep flame fluid away from heat source, sparks, fire or other possibility of ignition. Do not smoke!
- ∨ The operator responsible for the control of uFlamer PF10 must always have a clear view of the device, so that he/she can stop the show immediately when there is danger. The main AC power switch should near operator. So that operator can turn off the power of all devices in case of abnormal.
- ∨ The device shall not be altered and applied to other use purpose.

▲ Safety Distance

Keep minimum 15m in projection direction and 5m to the other sides of the device.

▲ Disclaimers:

SHOWVEN technologies Co., Ltd excludes liability for unsafe situations, accidents and damages resulting from:

1. Ignoring warnings or regulations as shown on uFlamer PF10 or this manual.
2. Use for other applications or circumstances other than those indicated herein.
3. Changes to the uFlamer PF10, including use of non-original spare parts, lack of maintenance etc.
4. Dismantling uFlamer PF10 without authorization from SHOWVEN.
5. Use this machine by unqualified or untrained personnel.
6. Use other type of fuel instead of ISOPAR as indicated in this manual.
7. Improper use of machine.

▲ Fuels for SHOWVEN Flame System

1. Water content in fuel should less than 0.5%
2. For safety, please use fuel with flash point between 60-80°C, ISOPAR L are recommended.

▲ **Functional Characteristics**

- \\ IP67 rated waterproof, designed for outdoor installations
- \\ Dual solenoid valve for extra safety
- \\ Dual igniter ensure successful ignition
- \\ Flames up to 10m
- \\ Aluminum CNC machining structure
- \\ Oxidation treated housing, durable for outdoor installation
- \\ Highlight digital tube display convenient for remote debugging
- \\ Infrared remote control realizes non-contact setting
- \\ Built-in accumulator

▲ **Technical Specifications**

- \\ **Dimension:** 250×200×410mm
- \\ **Weight:** 15 kg
- \\ **Input:** 220V, 110V
- \\ **Quick Coupler:** ISO7241B G1/4 male
- \\ **Work Power:** 120W
- \\ **Waterproof Level:** IP67
- \\ **Work Pressure Range:** 8-10Bar
- \\ **Installation Angles:** Any angle even upside down
- \\ **Fuel:** ISOPAR L
- \\ **Accumulator:** YES
- \\ **Flame Height:** 8-10m(Nozzle M)
- \\ **Ignition:** Dual, high voltage electron ignition
- \\ **Fuel Consumption:** 60ml/s (Nozzle M), 30ml/s (Nozzle L)
- \\ **Control:** Direct ON-OFF voltage control or DMX
- \\ **Min. Firing Duration:** 0.1S
- \\ **Work Temp.:** -20 °C~50 °C

▲ **Structure**

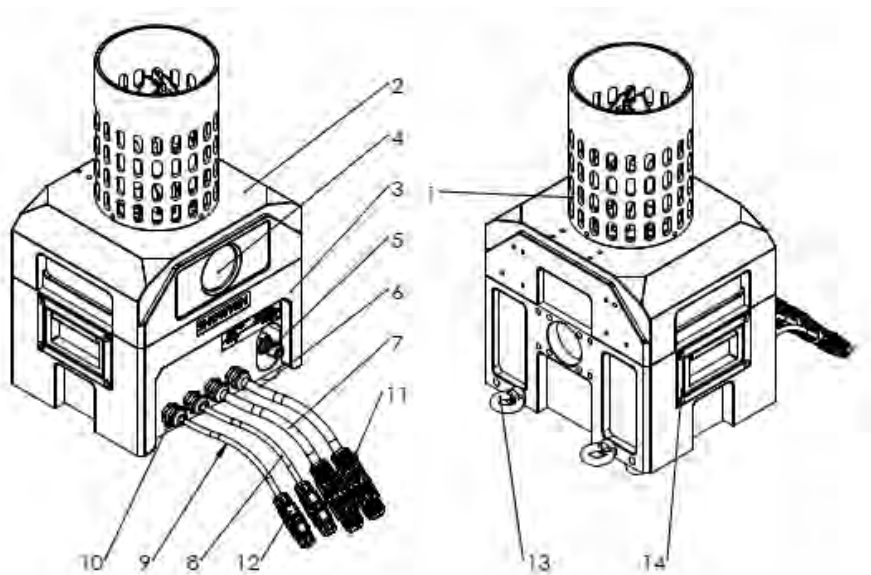

1. Flame chamber
2. Upper housing
3. Lower housing
4. Display panel
5. Quick coupler (ISO 7241B G1/4 male)
6. AC Power Input (BROWN: Live wire; BLUE: Neutral wire; Yellow: Ground wire), wire length 1m.
7. AC Power Output (BROWN: Live wire; BLUE: Neutral wire; Yellow: Ground wire), wire length 1m.
8. 3-PIN DMX IN (1 Ground: shield; 2 negative: white; 3 positive: red), wire length 1m
9. 3-PIN DMX OUT (1 Ground: shield; 2 negative: white; 3 positive: red), wire length 1m
10. Waterproof wire outlet
11. Waterproof connector EM20 3P
12. Waterproof connector EM15 3P
13. Safety loop
14. Handle

Diagram of bottom panel

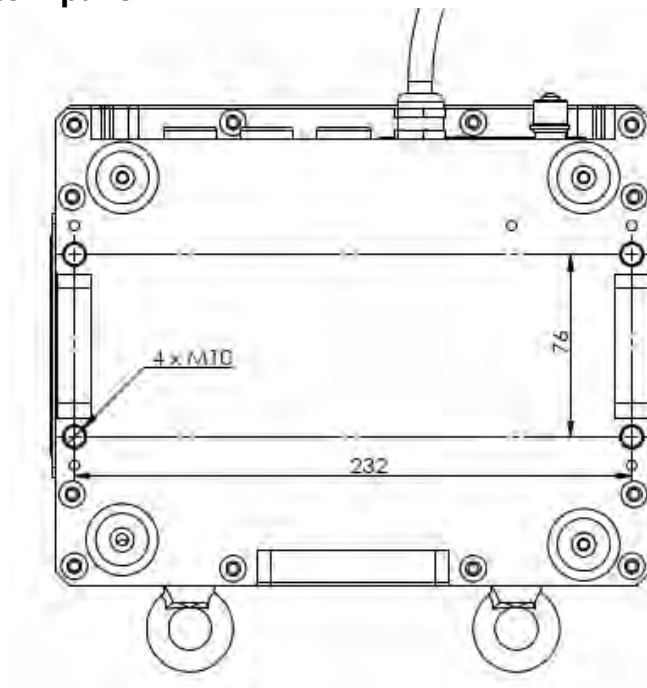

▲ Display and setting

1. Display area

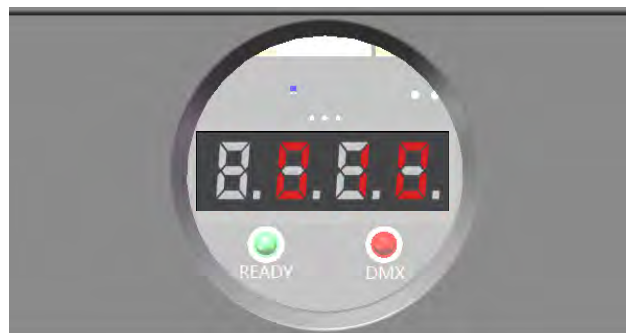

Digital tube display: shows the machine information

Ready indicator light: upper limit > current pressure \geq setting lower limit, this light on, means machine is ready to work

DMX indicator light: When DMX signal available, light blinks

When turn on machine READY and DMX indicator light will blink twice simultaneously.



2. Infrared remote

A+ CH1: Value up

B- CH2: Value down

C< CH3: Unlock and menu switch. Press and hold 10s can unlock the machine, the point in the bottom right corner of the digital tube display is flashing after unlock, operator can press to switch the menu and set up for PF10. If not press any key in 30s, it will lock automatically.

D< CH4: Confirm / Save. Please press this key after set any parameter.

NOTE:

1. If just want to change the setting for a single unit of PF10. When unlocking, keep the remote control close to the screen glass to prevent unlocking the next machine by mistake.
2. Unlock the machine before setting up.

3. Indicator light

Indicator light	Status	Explanation
READY light	Long ON	upper limit > current pressure ≥ setting lower limit
	OFF	current pressure < setting lower limit,
	BLINK	current pressure > upper limit
DMX light	BLINK	When DMX signal available

4. Welcome interface

Machine will self-test all LED light by turn them on. Then display the version information, for example first display PF22, 2s later display 0323 means the software version is PF220323.

5. Digital Tube display instruction

数码管显示英文字母							
显示	含义	显示	含义	显示	含义	显示	含义
	0		9		I		R
	1		A		J		S
	2		B		K		T
	3		C		L		U
	4		D		M		V
	5		E		N		W
	6		F		O		X
	7		G		P		Y
	8		H		Q		Z

6. Main interface



C2N and C6CH channel mode, the display information as below:

CXXX: Channel mode. C2P is safety channel mode, C2N is 2 channel mode; C6CH is 6 channel mode.

DXXX: Firing channel address. Eg: D001 means firing channel DMX address is 1;

PXXX: Current pressure display. Eg: P100 (100=10bar)

C2P channel mode, the display information as below:

CXXX: Channel mode. C2P is safety channel mode, C2N is 2 channel mode; C6CH is 6 channel mode.

FXXX: Firing channel address. Eg: F001 means firing channel DMX address is 1;

SXXX: Safety channel address. Eg: S002 means safety channel DMX address is 2;

PXXX: Current pressure display. Eg: P100 = 10bar.

When channel mode is C2P, CXXX, FXXX, SXXX and PXXX display by turns. When channel mode is C2N and C6CH, CXXX, DXXX, PXXX display by turns.

7. Menu Information

Press and hold C< CH3 for 10s to unlock PF10 and enter menu, press C< CH3 to switch menu.

Channel mode: C2N or C6CH

Menu	Range	Default value	Explanation
DXXX	1~512	1	DMX address
LXXX	ON/OFF	ON	Display and indicator light ON/OFF setting ON: Enable display and indicator light OFF: Display auto off in 30s after no signal from remote control
RXXX	90~180	150	Pressure upper limit. When pressure > 150, ready light BLINK.
BXXX	50-80	60	Pressure lower limit. 60 ≤ pressure <150, Ready light long ON When pressure < 60, Ready light OFF.
T00X	1 OR 2	--	Drive test 1: Ignition test, press confirm (D< CH4), ignition 3 times 2: Jet solenoid valve test: press confirm (D< CH4), jet valve ON/OFF 3 times
CXXX	0、1、2	0	Channel mode switch 0: C2P mode 1: C6CH mode 2: C2N mode
IXXX	0、1	0	Parameter initialization. Set to 1 and press confirm (D< CH4) parameter will initialization.

Channel mode: C2P

Menu	Range	Default value	Explanation
FXXX	1~512	1	DMX address
FXXX	1~512	2	Safety DMX address
LXXX	ON/OFF	ON	Display and indicator light ON/OFF setting ON: Enable display and indicator light OFF: Display auto off in 30s after no signal from remote control
RXXX	90~180	150	Pressure upper limit. When pressure > 150, ready light BLINK.
BXXX	50-80	60	Pressure lower limit.

			60 ≤ pressure <150, Ready light long ON When pressure < 60, Ready light OFF.
T00X	1 OR 2	--	Drive test 1: Ignition test, press confirm (D< CH4), ignition 3 times 2: Jet solenoid valve test: press confirm (D< CH4), jet valve ON/OFF 3 times
CXXX	0、1、2	0	Channel mode switch 0: C2P mode 1: C6CH mode 2: C2N mode
IXXX	0、1	0	Parameter initialization. Set to 1 and press confirm (D< CH4) parameter will initialization.

▲ DMX control

There are three channel mode switchable for PF10: C2P, C6CH and C2N.

C2P channel mode

Channel	DMX value and function
CH-F	Ignition channel 0~110: Ignition OFF 111~255: Ignition ON
CH-S	Mode setting 0~49: Test mode 50~200: User mode 201~255: Test mode In test mode, operator can test the ignition of PF10, but can't firing. In user mode, machines are armed.

F: control DMX address; S: safety DMX address.

C6CH channel mode

Channel	DMX value and function
CH1	--
CH2	--
CH3	Ignition channel 0~253: Ignition OFF 254~255: Ignition ON
CH4	Firing duration setting 0 and 255: keep firing (default firing duration limit is 8s) 1~254: corresponding to 10-2540ms firing duration (manual firing duration = DMX value * 10ms)
CH5	--
CH6	Mode setting 0~49: Test mode 50~200: User mode 201~255: Test mode In test mode, operator can test the ignition of PF10, but can't firing. In user mode, machines are armed.

C2N channel mode

Channel	DMX value and function
CH-1	Ignition channel 0~110: Ignition OFF 111~255: Ignition ON
CH-2	Mode setting 0~239: Test mode 240~255: User mode In test mode, operator can test the ignition of PF10, but can't firing. In user mode, machines are armed.

Note: When hose pressure ≥ 40 , PF10 can firing normally; When hose pressure < 40 , PF10 can ignition but jet solenoid valve can't open, thus can't firing.

Maximum designed firing duration is 8s.

▲ Nozzle Replacement

Use 14mm outer hexagon socket wrench to disassemble the nozzle, clean the nozzle and nozzle socket with air gun (air compressor), change a different nozzle and install it.

Nozzle disassemble tool: SFMET944



▲ Ignitor Position Adjustment

Whenever changed the nozzle or ignition is not good, please check ignitor pole position according to below parameters. The right position for each pair of pole should have a gap from tip to tip of 4 ± 0.5 mm and a gap between two ignitor of 13 ± 1 mm. Check the ignition success rate after adjustment by firing.

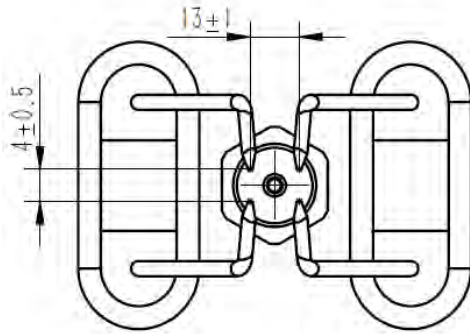

Note: Do unplug the power cable when service flamer.

▲ Maintenance

1. To maintain the system in good performance and running status, it is recommended to running the device at least once per month.
2. Maintenance of the nozzle: Nozzle needs to be cleaned from time to time, and it is recommended that once every six months (depending on the environment and frequency of use). In the process of using the equipment, if the flame shape is seriously deformed or the fuel injection line is significantly deformed or coarsened, the nozzle should be removed immediately for cleaning. If after clean, there are still problems please replace new nozzle.
3. Maintenance of the O-ring: If it is found that the O-ring of the nozzle is damaged or ageing when cleaning the nozzle, the O-ring should be replaced in time (material and size of O-ring: fluororubber O-ring, the outermost diameter is 14 mm, and the line diameter is 2 mm).

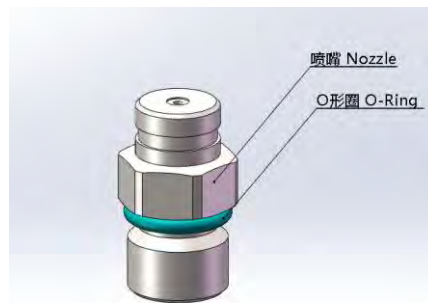

▲ Warranty Instructions

- ∨ Sincere thanks for your choosing our products, you will receive quality service from us
- ∨ The product warranty period is one year. If there are any quality problems within 7 days after shipping out from our factory, we can exchange a brand new same model machine for you
- ∨ We will offer free of charge maintenance service for machines which with hardware malfunction (except for the instrument damage caused by human factors) in warranty period. Please don't repair machine without factory permission

Below situations NOT included in warranty service:

- ∨ Damage caused by improper transportation, usage, management, and maintenance, or damage caused by human factors;
- ∨ Disassemble, modify or repair products without permission;
- ∨ Damage caused by external reasons (lightning strike, power supply etc.)
- ∨ Damage caused by improper installation or use;

For product damage not included in warranty range, we can provide paid service.

Invoice is necessary when applying for maintenance service from SHOWVEN

SHOWVEN[®]

PREMIUM FACTORY SAS - DISTRIBUTEUR OFFICIEL
1 Route Neuve, 71710 MONTCENIS - FRANCE Office
+33 805 69 13 27 | +33 608 630 452
info@premiumfactory.eu | www.premiumfactory.eu