

USER MANUAL

U-FLAMER

V2.1

2022/09



Showven Technologies Co., Ltd.

△ Foreword

Thanks for choosing SHOWVEN U-Flamer, we wish it will bring you lots of exciting moments. Please read the following manual carefully before operating this product. Operate according to instructions is very important for safety, and can elongate the service life of the machine. Strictly follow the instruction in the manual when operate U-Flamer. If you have any doubts, please contact SHOWVEN technologies Co., Ltd by info@showven.cn

We assume the person who use or come in contact with the device are familiar with how the device should be handled. This includes proper use, maintenance and repair of the machine as defined in this user manual.

△ Warning

- \\ This product is only suitable for qualified or skilled operators who has experience with the technology of the device and is particularly informed about the types of fuel used by the device.
- \\ Unauthorized repair are prohibited, it may cause serious incident
- \\ Make sure power supply in consistent with the rated voltage of the equipment, and the socket must well grounded. Unplug and turn off the machine when not use
- \\ Before connect the power cable, communication DMX cable should well connected and ensure the command keep at firing OFF status. And safety lock of U-Flamer stay at TEST MODE.
- \\ Before power on the machine, please check carefully the safety distance and make sure it meets the requirements in this manual.
- \\ The device can only be placed on the ground, straight.
- \\ After turning on the device, no person allows to stay in the danger area. Ensure all persons that are part of the show be informed about the safety distance, risks and functions of the device
- \\ Always have a CO2 fire extinguisher and an extinguishing blanket in case of needed
- \\ If there be any doubt as to the safety operation of the device in any circumstances, the device should be taken out of service immediately. Be sure the device is in good operating condition before use. If fail to fire correctly, immediately shut down and check it accordingly
- \\ Be sure to use high quality flame fluid, otherwise, it is easily leads to failure or danger. Be careful when refill the flame fluid tank. Please keep flame fluid away from heat source, sparks, fire or other possibility of ignition. Do not smoke!
- \\ The operator responsible for the control of U-Flamer must always have a clear view of the device, so that he/she can stop the show immediately when there is danger. The main AC power switch should near operator. So that operator can turn off the power of all devices in case of abnormal
- \\ The device shall not be altered and applied to other use purpose

△ Disclaimers

SHOWVEN technologies Co., Ltd. excludes liability for unsafe situations, accidents and damages resulting from:

1. Ignoring warnings or regulations as shown on flamer or this manual.
2. Use for other applications or circumstances other than those indicated herein.
3. Changes to the flamer, including use of non-original spare parts.
4. Removed safety cover without authorization from SHOWVEN.
5. Use this machine by unqualified or untrained personnel.
6. Improper use of machine.

▲ **Functional Characteristics**

- \\ Fluid driven vertical flamer original designed by SHOWVEN
- \\ Flame up to 8-10m, indoor nozzle optional
- \\ Dual igniter, built-in pump, plug and play system
- \\ Super compact pumping system design, easy carrying
- \\ Stainless steel housing, IPX3 waterproof design, reliable and durable
- \\ Built-in 5L fuel tank, no external hose connection needed
- \\ Safety lock with switchable test mode, safer for service
- \\ Tilt protection, the tilt sensor will be activated when machine slant Over 45°
- \\ Intelligent control system, safer for use
- \\ Standard DMX control, compatible with all DMX console
- \\ Neutrik® powerCON TRUE1 connectors
- \\ Built-in battery optional

▲ **Technical Specifications**

- \\ **Model:** U-Flamer
- \\ **DIMENSION:** 330× 260× 320mm
- \\ **WEIGHT:** 14kg
- \\ **VOLTAGE:** 100-240V, 50/60Hz
- \\ **POWER:** 300W
- \\ **CONTROL:** DMX
- \\ **INTERFACE:** 3-pin&5-pin DMX IN/OUT
- \\ **FLAME HEIGHT:** 8-10m (no wind)
- \\ **FUEL:** ISOPROPANEL, ISOPAR-G,H,L,M
- \\ **FUEL TANK CAPACITY:** 5L
- \\ **FUEL CONSUMPTION RATE:** 60ml/s
- \\ **FUEL LEVEL SENSOR:** YES
- \\ **EFFECT DIRECTION:** Vertical
- \\ **IGNITION:** High voltage electron ignition
- \\ **IGNITOR:** Dual
- \\ **BUILT-IN BATTERY:** OPTIONAL
- \\ **USAGE IN RAIN:** YES

▲ **Structure of U-Flamer**

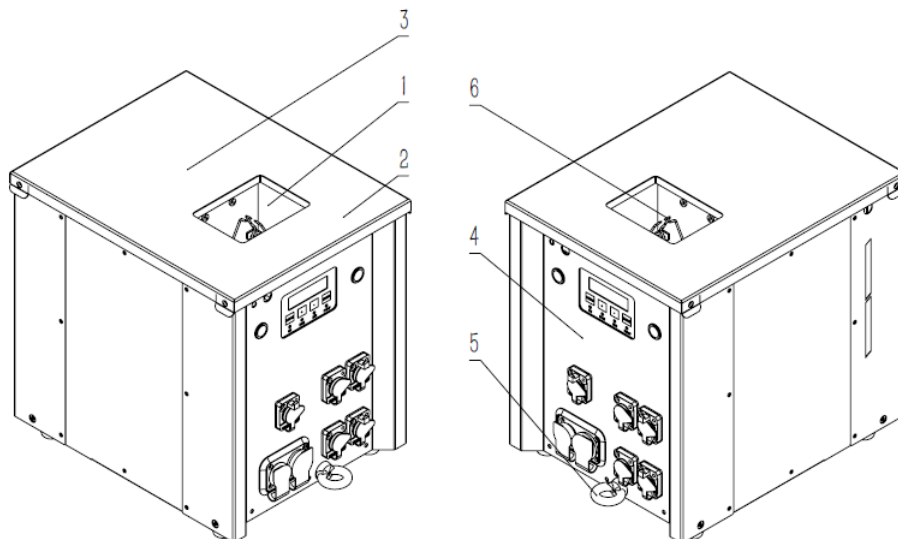

1. Firing Box
2. Top Panel
3. Fuel Bottle Area
4. Control Panel
5. Safety Loop
6. Igniter (dual)

Overview of Bottom Panel

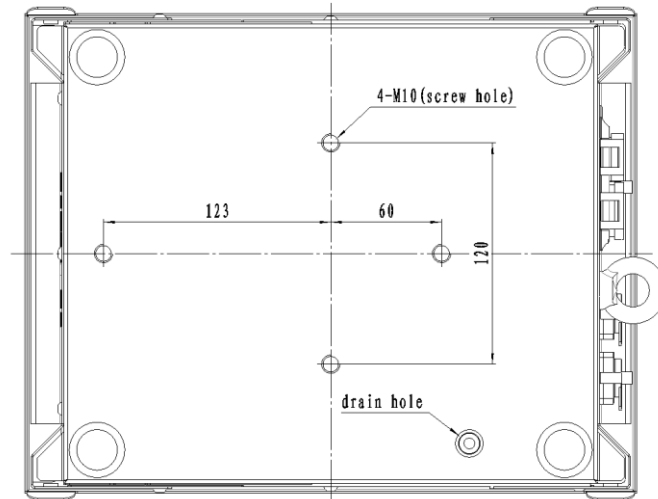

Overview of Control Panel

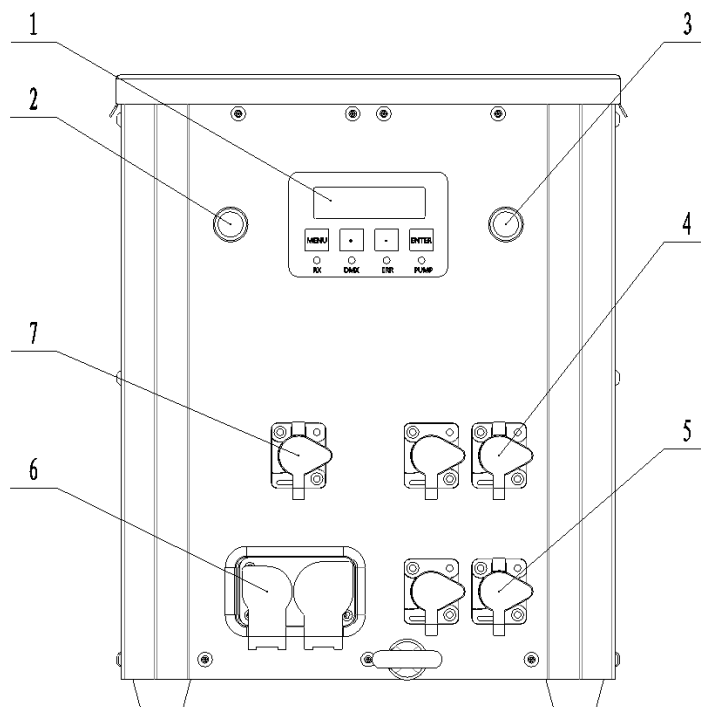

1. LCD screen operate panel
2. ON/OFF switch (pressurized indicator light, blue LED)
3. Safety Lock (safety indicator light, red LED)
4. 3-pin DMX socket
5. 5-pin DMX socket (Wireless DMX512 power DC5V between 1 and 4 pin)
6. Power socket
7. Charging Input

△ Operation Panel

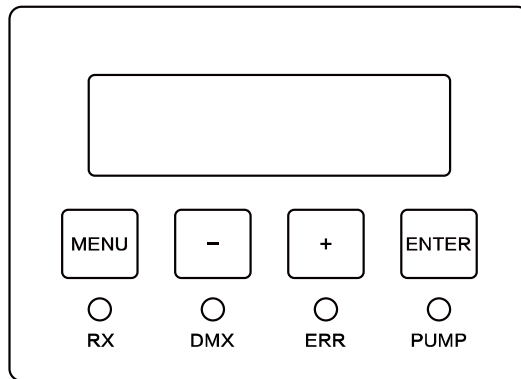

1. LED Display Area:

RX: Radio receiving (reserved)

DMX: DMX signal. Flash means DMX signal available, otherwise no DMX signal

ERR: Light on when there is an error

PUMP: Light on when pump is running

2. Button Functions:

MENU: Switch interface to setup parameter;

+: Parameter Up

-: Parameter Down

ENTER: Confirm and save parameters (screen will flash when parameters saved)

Note: screen display will switch to main interface if there is no operation in 15s.

3. Welcome Interface :



First Line: Product model and software version

Second Line: Equipment series number

4. Main Interface:

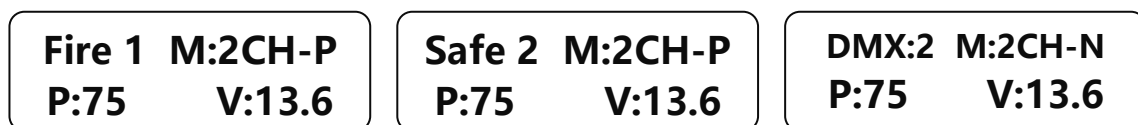

First Line:

Operational DMX address (FIRE) and Safety DMX address (safe) under DMX Channel Mode 2CH-P; DMX address under DMX Channel Mode 6CH and 2CH-N;

Second Line: Pressure 75 (e.g. 100=10bar); V: 13.6 means internal voltage is 13.6V.

5. Alert Message:

Alert Message	Why it appears	How to remove
E0 Test Mode	Safety Switch at TEST MODE	Switch to USER MODE
E0 Factory Mode	Factory mode	Switch to Normal mode

6. Error Message:

Error Message	Why it appears	Reason / How to remove
E1 Pressure Err	Pressurize for 8s, pressure value failed to reach target	No fuel, pump failure, pipeline leakage etc reason, please check accordingly
E2 P Relief Err	Depressurize value for 3s, pressure value \geq 50% of target value	Pressure relief valve failure
E5 Voltage Err	DC input < 11V or > 18V	Make sure DC input between 11-18V
E6 Tip Err	Machine slant over 45°	Tip setting set to OFF, or horizontal install machine
E7 Low Fuel	Fuel level low	Fill the tank or Switch OFF the liquid level sensor

7. Interface setup:

Press "MENU" to switch through setup menu, press and hold "MENU" 3s back to main interface.

DMX Channel Mode	Menu	Range	Explanation
6CH / 2CH-N	Set DMX Address	1~511	DMX address setup
2CH-P	Fire Address	1~511	Fire address setup
	Safety Address	1~512	Safety address setup

8. Advanced Interface:

Press "MENU" 3s enter advanced interface, press "MENU" to switch interface, press "MENU" 3s can back to main interface. The value in bold character is default value.

Items	Contents	Description
Drive Test	OFF / Pump / Igniter / Relief Valve / Jet Valve	
	1. Pump	Pump running, if pressure reached the target value, the pump will not running.
	2. Igniter	Ignite 1s
	3. Relief Valve	Relief valve will be on and off for 3 times
	4. Jet Valve 1	Safety lock located at user mode, release pressure for a period of time, jet valve will be on and off for 3 times
	5. Jet Valve 2 (none)	
Language	English / Chinese	Language switch
Mode Select	Normal Mode / Factory Mode	Factory mode is for test in factory only
Tip setting	ON / OFF	Turn ON/OFF tip over function
DMX Channel Mode	2CH-P / 6CH / 2CH-N	Change the DMX Channel Mode.
Low Fuel Switch	ON / OFF	Turn ON/OFF the fuel level sensor
Default Parameter	OFF / ON	Reset default parameter settings

▲ DMX CONTROL

U-Flamer with 3 different channel mode: 2CH-P, 2CH-N and 6CH.

2CH-P:

In this channel mode U-Flamer occupies 1 functional channel and 1 separate safety channel (this channel is independent from operational channel, can be shared with other machine).

Channel	Function	Value
---------	----------	-------

Functional Channel	Firing	0~110: Firing OFF 111~255: Firing ON
Safety Channel	Device enable / disable	0~49: Depressurize mode, disable device (Emergency STOP) 50~200: Pressurize mode, enable device 201~255: Depressurize mode, disable device (Emergency STOP)

2CH-N:

In this channel mode U-Flamer occupies 2 functional

Channel	Function	Value
CH-1	Firing	0~110: Firing OFF 111~255: Firing ON
CH-2	Pressurize / Depressurize	0~239: Depressurize mode (Emergency STOP) 240~255: Pressurize mode, enable device

6CH:

In this channel mode U-Flamer occupies 6 functional channel. This channel mode is designed to control the U-Flamer together with CIRCLE FLAMER on our Host Controller.

Channel	Function	Value
CH1	-	-
CH2	-	-
CH3	Firing ON/OFF	0~253: Firing OFF 254~255: Firing ON
CH4	Firing Duration setup	0 and 255: permanent fire (8s is limit duration time) 1~254: 10~2540ms duration time (Manual firing duration = DMX Value * 10ms)
CH5	-	-
CH6	Pressurize / Depressurize	0~49: Depressurize (Emergency Stop) 50~200: Pressurize 201~255: Depressurize (Emergency Stop)

▲ Control with SHOWVEN Host Controller ZK6200/ZK6300

If use SHOWVEN Host Controller ZK6200 or ZK6300 to program the U-Flamer, after set DMX channel mode on U-Flamer please also set on Host Controller. The setting step is:

Press “F3” on Host Controller – find “Device” – choose the right device “CIRCLE FLAMER” (6CH mode). Host Controller with bi-directional communication with device, please allocate a unique DMX address for each unit of U-Flamer.

FIRING HEIGHT is meaningless, just need to set the FIRING DURATION.

```

F3 CONFIG
StartNo.      : 1
End No.       : 10
Device        : CIRCLE FLAMER
Mode Selection : User Mode
Repeat Time Mode : Repeat Period Mode
DMX IN        : ON
DMX Address   : 1
CAN           : OFF
Trigger Source : HAND
Audio Level   : 2
Audio Filter Delay : 100ms

```

```

F1 MAN
Synchronization CIRCLE FLAMER No. 1-10
FILE | FIRING | FIRING | TRIG | REPEAT | REPEAT
NO.  | HEIGHT | DURTN  | DELAY | DELAY | COUNTS
  1  |    31  | 0.5s  | 0.0s  | 10.0s | 1
Terminal Monitor
1 2 3 4 5 6
7 8 9 10 11 12
13 14 15 16 17 18
From 1-15 Stepsequence short 2.4s
MAN FILE SELECT CONFIG ABOUT

```

▲ Operation

1. Safety Distance

Definition and Instructions

Safety distance for U-Flamer divided into two parts safety radius around machine (a) and safety distance at firing direction (b). No person and flammable materials are allowed to stay inside the safety isolation zone when flamer was armed.

The safety radius around machine depends on the firing height (nozzle size), with a radius from 2.5m to 3m.

For safety distance at firing direction equals to maximum firing height * 1.5.

Nozzle Type	Max. Flame Height	Safety Radius around U-Flamer (a)	Safety Distance at Firing Direction (b)
SFSMA002 Nozzle M	10m	3m	15m
SFSMA003 Nozzle L	8m	2.5m	12m

The U-Flamer safety isolation zone (show as below) is a cylindrical three-dimensional space with Safety radius around machine (a) and Height of b. Unauthorized persons and objects are strictly prohibited from entering.

For angled installation, the safety distance both around machine and firing direction should shift accordingly.

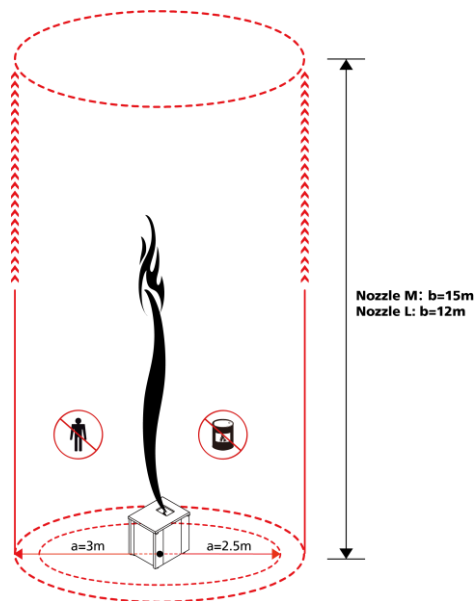

Safety distance in windy environment

The safety isolation zone radius (a) and safety distance of firing direction (b) increase with wind direction and wind speed (v, m/s). The safety distance in windy conditions can be calculated as below:

For Nozzle M: $a = 3 + v$; $b = 15 + v$

For Nozzle L: $a = 2.5 + v$; $b = 12 + v$

For example when the wind speed is 3m/s, we use the Nozzle M on U-Flamer, then the safety isolation zone radius should be 6m, safety distance of firing direction is 18m.

When the wind speed $\geq 8\text{m/s}$ (wind force ≥ 5), please use it with caution. When wind speed $\geq 17\text{m/s}$ (wind force ≥ 8), please stop use uFlamer.

Safety mark

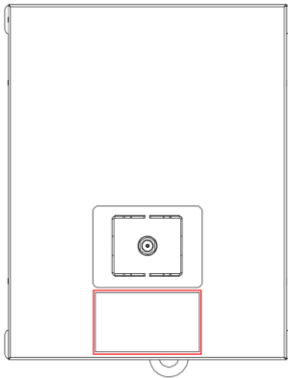

Never point the flamer on humans, animals, fire hazardous substances or other sensitive items.
 Always disconnect the power supply before any physical contact with the flamer.
 Never store the flamer under pressure.
 Always contact SHOWVEN if necessary.

Label of U-Flamer

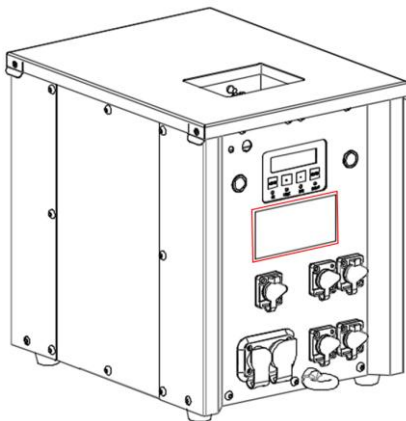

uFlamer		SHOWVEN®
AC 100V-240V 50/60Hz	300W	
Showven Technologies Co.,Ltd. www.showven.cn info@showven.cn +86-731-83833068 No.1 Tengda Road, Liuyang Economic & Technical Development Zone, 410300, Changsha, Hunan, P.R.China		CE, RoHS, and other compliance icons MADE IN CHINA
	Hazardous voltage inside, please do not remove the cover unless by trained personnel.	Serial Number
	People and flammable materials should keep a certain safety distance around the machine and in the firing directions. Check user manual for detail safety distance information.	 9 788087 049099

Fuels for U-Flamer

1. Water content in fuel should less than 0.5%
 2. For maximum safety, please use fuel with flash point between 60-80°C, ISOPAR L is highly recommended.
 3. Ethanol is not suggested due to three reasons, first ethanol is highly flammable makes it not as safe as ISOPAR; secondly the color of flame is very weak; thirdly there are always high water content (> 0.5%) in ethanol.
 4. Colored fuels are forbidden to use on U-Flamer it may damage the machine.
- SHOWVEN excludes liability for the losses, damages and accidents caused by not using qualified fuels in accordance with this requirement.
- Always have a dry powder fire extinguisher, a CO₂ fire extinguisher and an extinguishing blanket next to the equipment in case of needed. And someone must be on duty during operation. In case accident occurs, a dry powder fire extinguisher can be used when the fire is large, and a carbon dioxide fire extinguisher can be used when the fire is small.

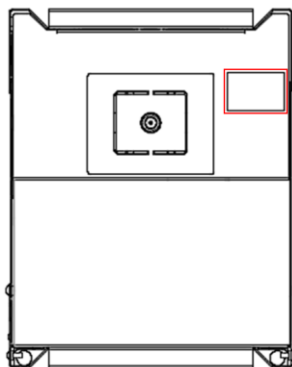

FUEL INFORMATION ISOPROPANOL ISOPAR G,H,L,M

2. Install uFlamer

- Choose the correct nozzle, ensure the installation position of U-Flamer meet above safe distance requirements. New U-Flamer supplied with a nozzle M which generate up to 10m flame.
- Horizontal installation is preferred for U-Flamer. If need to install U-Flamer in angles, to avoid fake error message please turn the TIP Setting and Low fuel switch to OFF status first. U-Flamer with maximum tilt angle of 45° or -45° , and it can be angled to two directions as show in below picture. Besides please be aware the fuel level in fuel tank to avoid fuel leakage when tilt installation.
- For truss installations always connect with safety rope to ensure extra safety. If there is any other national or regional guidelines please follow it accordingly.
- Double confirm the machine was firmly installed.

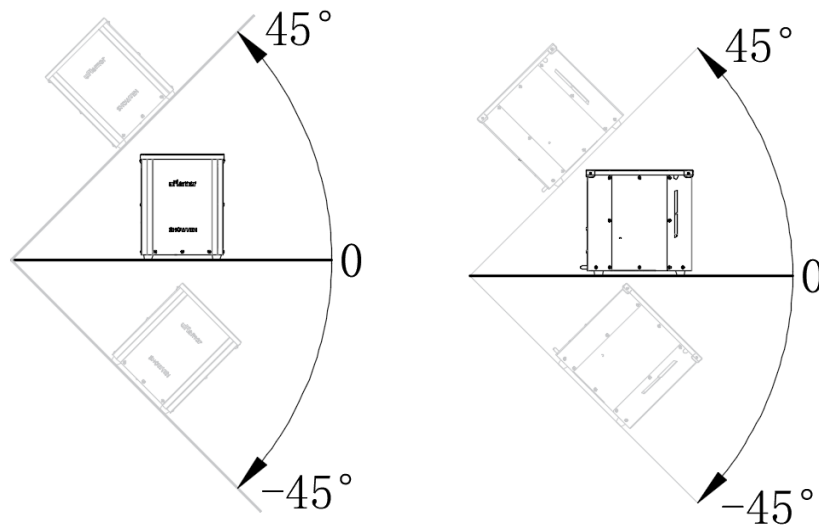

3. Connect Power and DMX cable to uFlamer

Before power and/or DMX cable connection, make sure safety button of U-Flamer stay at TEST MODE. When safety button is pressed down, it is USER MODE; when it pops up, it is TEST MODE. So before connect power and DMX cable make sure the safety button of U-Flamer pops up.

- Connect a power cable to the POWER IN socket of U-Flamer. Connect the other end of power cable to the power source. Make sure power supply is consistent with the rated voltage of the equipment, and the socket must well grounded.
- Each unit of U-Flamer can be connected to power supply directly. If connect machine in sequence, please connect a power link cable to the POWER OUT of previous machine, connect the other end of the power link cable to POWER IN of the next machine. Do not connect exceed units to a single electrical circuit.
- Power on all U-Flamer. Check the safety button, double confirm it stays at "TEST MODE" .

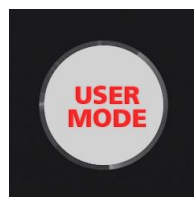

USER MODE

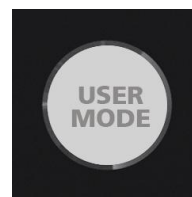

TEST MODE

- Assign DMX address for each unit of U-Flamer. If use SHOWVEN host controller or FXcommander to control the machine please allocate a unique DMX address for each unit of machine.
- Connect a DMX cable to the DMX IN socket of first unit of U-Flamer, another head of this DMX cable connect to DMX console (such as FXcommander). **Make sure the DMX console is powered off.**
- Connect a DMX cable to the DMX OUT socket of previous U-Flamer, and the other end to the DMX IN of next machine. Connect all devices in series in this way.
- Suggest to plug in a DMX terminator into the DMX OUT in last unit of machine to improve signal reliability. Signal amplifier is required for long distance ($>200\text{m}$) DMX signal transmission.

4. Power ON the DMX console and programming

Power on DMX console and program the U-Flamer effect on DMX console

5. Test the ignition function of U-Flamer

Test the ignition function of U-Flamer, we can check whether the igniters of each unit of U-Flamer is working fine. Due to the safety switch is stay at TEST MODE the pump won't work, there will be only ignition while no fuel spray out, so no flames generated.

6. Fill the U-Flamer

Please fill the machine with qualified fuel. The fuels suggested on U-Flamer are ISOPAR, ISOPROPANOL, please make sure water content in fuel should less than 0.5%.

7. Firing

- a) Double confirm the prescribed safety isolation zone is clear, no person, animal or other property within this region.
- b) Switch the safety button of U-Flamer to USER MODE.

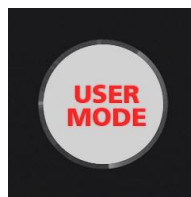

- c) Pressurize U-Flamer.
- d) Firing, the operator should always have a clear view of the device, so that he/she can stop the show immediately when there is danger.

8. Depressurize

Depressurize all U-Flamer after use or if not use for a long time during the show we also suggest to depressurize to ensure the safety.

9. Power OFF

- a) Power OFF DMX console
- b) Switch safety switch of U-Flamer to TEST MODE
- c) Power OFF uFlamer
- d) Unplug power cable, DMX cable.

▲ Nozzles and Nozzle Replacement

Nozzles

There are two types of Nozzle for U-Flamer. Nozzle M and Nozzle L.

Nozzle M: (standard configuration)

Short flame: 5-7m,

Long flame: 8-10m.

Nozzle L:

Short flame: 3-5m,

Long flame: 6-8m.

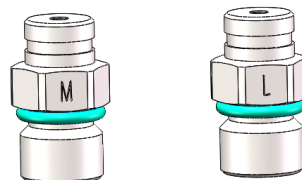

Nozzle Replacement

Use 14mm outer hexagon socket wrench to disassemble the nozzle, clean the nozzle and nozzle socket with air gun (air compressor), change a different nozzle and install it.



▲ Igniter Position Adjustment

Whenever changed the nozzle or ignition is not good, please check igniter pole position according to below parameters. The right position for each pair of pole should have a gap from tip to tip of 4 ± 0.5 mm and a gap between two igniter of 13 ± 1 mm. Check the ignition success rate after adjustment by firing.

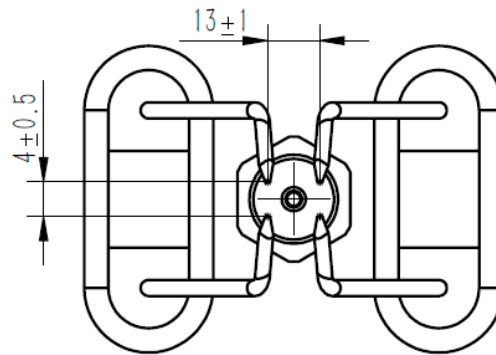

Note: Do unplug the power cable when service flamer.

▲ Battery Recommendation

U-Flamer can be driven by battery, you can order battery from us directly or buy it locally. The battery specifications are as below:

Capacity	5200mah 20c-70c
Voltage	14.8V
Size	140*43*44mm (L*H*W)
Charge Jack	2.54-5A
Discharge Jack	XT60
Installation	Contact SHOWVEN sales for installation guide/video

▲ Maintenance

1. To maintain the system in good performance and running status, it is recommended to running the device at least once per month.
2. Check the ignition probes both before and after each show, if there is any foreign objects on it please clean it up.
3. Maintenance of the nozzle: Nozzle needs to be cleaned from time to time, and it is recommended that once every six months (depending on the environment and frequency of use). In the process of using the equipment, if the flame shape is seriously deformed or the fuel injection line is significantly

deformed or coarsened, the nozzle should be removed immediately for cleaning. If after clean, there are still problems please replace new nozzle.

4. Maintenance of the O-ring: If it is found that the O-ring of the nozzle is damaged or ageing when cleaning the nozzle, the O-ring should be replaced in time (material and size of O-ring: fluororubber O-ring, the outermost diameter is 14 mm, and the line diameter is 2 mm).

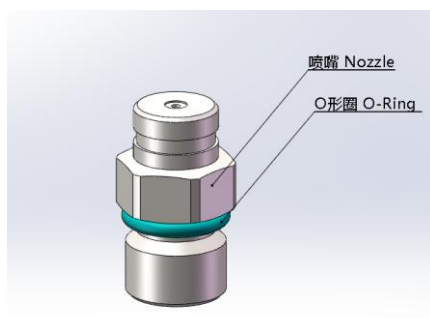

▲ Optional Parts for U-Flamer

Part. No.	Description	pcs / unit
RMWAS025	O ring for nozzle	1
RMBOT036	Safety ring	1
RMMET045	Safety rope	1
RMEMD062	Wireless receiver (for wireless control with FXcommander)	1
SFSMA002	nozzle M	1
SFSMA003	nozzle L	1
SFMET944	Nozzle disassemble tool	1
RMSPS029	5500MAH 50C 14.8V 4S XT60 Lithium Battery	2
SFCAB100	Connection cable between RC battery charger and U-Flamer	1
RMEMD057	HOT RC Lithium Battery Charger A400	1
RMCAB083	EU power cord for HOT RC Charger A400 (For EU only)	1
FPFLI026	U-Flamer Flightcase 2in1	1
SFCAB065	Waterproof DMX cable, 6m	1

△ Warranty Instructions

- \ Sincere thanks for your choosing our products, you will receive quality service from us
- \ The product warranty period is one year. If there are any quality problems within 7 days after shipping
 - out from our factory, we can exchange a brand new same model machine for you
- \ We will offer free of charge maintenance service for machines which with hardware malfunction (except for the instrument damage caused by human factors) in warranty period. Please don't repair machine without factory permission

Below situations NOT included in warranty service:

- \ Damage caused by use unqualified fuels;
- \ Damage caused by improper transportation, usage, management, and maintenance, or damage caused
 - by human factors;
- \ Disassemble, modify or repair products without permission;
- \ Damage caused by external reasons (lightning strike, power supply etc.)
- \ Damage caused by improper installation or use;

For product damage not included in warranty range, we can provide paid service.

Invoice is necessary when applying for maintenance service from SHOWVEN

SHOWVEN®

PREMIUM FACTORY SAS - DISTRIBUTEUR OFFICIEL
1 Route Neuve, 71710 MONTCENIS – FRANCE Office
+33 805 69 13 27 | +33 608 630 452
info@premiumfactory.eu | www.premiumfactory.eu