

## United Compact Foam

Item Code: UFXFOAM-1

The United Compact Foam is compact, highly efficient and ultra quiet thanks to its high-tech centrifugal fan. It is completely adapted to the uses in Theater, Opera and TV.  
This machine is connected directly to the water network with an automatic mixer by venturi suction system. It comes with its support, its 5L drum, 2 pipes (10 and 15m) and a quick connector for connection to the water network. Professional connection and resettable fuse.

### NOMENCLATURE :

- 1 x United Compact Foam
- 1 x Bottle Holder 5 L
- 1 x Hoses of 10 & 15 meters
- 1 x Power supply IEC 1.5m



### TECHNICAL SPECIFICATIONS :

Size : Lg 57.2 x lg 39.4 x Ht 48 cm  
Weight : 19 Kg

#### Electrical Specifications:

230V – 50/60Hz – 1000W – 4.3A – IP 44 (Version Europe)  
115V – 60Hz – 1000W – 4.3A – IP 44 (Version US)

### FEATURES :

Injection of the foam liquid by venturi system.  
Production of 30m<sup>2</sup> / min of foam.  
Consumption in United Foam / Snow CC (concentrated foam liquid): 10 L / h.  
Direct connection to the water network.  
The ideal water pressure required is 3 Bar.  
Minimum pressure of 1 bar.  
Maximum pressure of 5 bar.

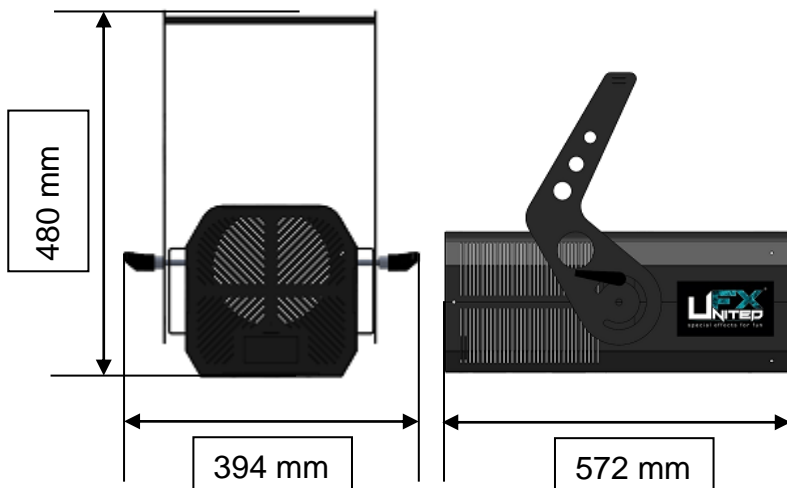

### CONSUMABLES :

- XT- Foam Fluid LC
- XT- Foam Fluid CC
- XT- Foam Fluid HC

### OPTIONAL ACCESSORIES :

- United Ground Foot FX
- UE Box Switch or Dimmer

Made of STEEL, the United Compact Foam is built to last. Each element has been chosen for its quality and efficiency.

**United FX, La Marque Simple et Extraordinaire Fabriqué en France**